

Operation elements and connectors









- | | |
|--|---|
| <p>1 Switch for start number input with three positions:
 up: increment up automatically as each racer starts
 middle: manual input of start numbers with keyboard (9)
 down: increment down automatically as each racer starts</p> <p>2 Display for the start</p> <p>3 External supply LED status light</p> <p>4 Meter for monitoring power supply, alignment of the photocell (c1 to c9)</p> <p>5 View port to examine paper supply</p> <p>6 Info-display 4 x 40 alphanumeric characters</p> <p>7 Display that shows the running and net time that corresponds with the start number input on the finish keyboard (15)</p> <p>8 Display that show the start number input for finish</p> <p>9 Start keyboard:
 START manual start impulse
 CLEAR clear false start
 BLOCK blocks start impulses for as long as you press it
 INPUT edit start times
 ENTER confirm input
 0 to 9 numeric keys to input start numbers for the start or editing start times</p> <p>10 paper advance wheel</p> <p>11 cover release button to open the printer cover (13) to change the paper
 12 paper cutter</p> <p>13 printer cover (open with cover release button 11)</p> <p>14 Function keyboard:
 YES key to confirm YES/NO questions
 NO key to deny YES/NO questions
 PRINT to switch the printer on and off
 PRINT: Buffer mode on or off
  + PRINT: Printer on or off
 TEST info-display (6) shows the device test
  key to go up
  key to go down
  key for special functions
 CLASS key to make a classement
 MEMO to activate the memo function if more competitors reach the finish at the same time
 MENU press this key first, followed by another to activate a special function: With <ALT> and <MENU> you get into the main menu
  press this key first, followed by another to activate a special function: With <ALT> and <PRINT> you toggle the printer on and off.
  function key 1 on info-display
  function key 2 on info-display
  function key 3 on info-display
  function key 4 on info-display</p> | <p>15 Finish keyboard:
 STOP manual stop impulse
 CLEAR clear false finish
 BLOCK blocks finish impulses for as long as you press it
 INPUT edit of finish times
 ENTER confirm input
 0 to 9 numeric keys to input start numbers for the finish or editing finish times</p> <p>16 Connection for Extender and Multi Channel (channel 0 to 9)</p> <p>17 Volume for headset</p> <p>18 Jack for the headset</p> <p>19 DIN-jack mainly used to connect the finish photocell (inputs c0, c1, c2). Connection of power supply is possible. Identical with DIN-jack (20)</p> <p>20 DIN-jack mainly used to connect the finish photocell (inputs c0, c1, c2). Connection of power supply is possible. Identical with DIN-jack (19)</p> <p>21 DIN-jack mainly used to connect the a intermediate photocell (inputs c3, c4, c5). Connection of power supply is possible.</p> <p>22 DIN-jack mainly used to connect the a intermediate photocell (inputs c6, c7, c8). Connection of power supply is possible.</p> <p>23 Two identical DIN-jacks with RS-232 and RS-485 interface.</p> <p>24 DIN-jack to connect a ALGE display board.</p> <p>25 DIN-jack to connect a speaker (e.g. show jumping)</p> <p>26 On / Off - switch</p> <p>27 banana socket for all 10 timing channels. The four black jacks are common grounds for all channels.
 c0 Start channel
 c1 finish channel
 c2 intermediate time 1
 c3 intermediate time 2
 c4 intermediate time 3
 c5 intermediate time 4
 c6 intermediate time 5
 c7 intermediate time 6
 c8 intermediate time 7
 c9 intermediate time 8</p> <p>28 Banana socket for RS-485</p> |
|--|---|

Table of Contents

1.	DEVICE DESCRIPTION	6
1.1.	Standard software	7
2.	OPERATING	8
2.1.	Power Supply	8
2.1.1.	Net-Charging-Set NLG8	8
2.1.2.	External Battery (12 V car battery)	9
2.1.3.	Working Time	9
2.1.4.	Condition of the Rechargeable Battery	9
2.2.	Printer	10
2.3.	How to Connect other Devices with the TdC 8000	12
2.4.	Memory	15
2.4.1.	Memory Organisation	15
2.4.2.	Clear Memory	15
2.5.	Select a Race	16
2.6.	Precision	16
2.7.	Timing Modes	17
2.8.	Input of Groups	18
2.9.	Test-Functions - Checking the TdC 8000	18
2.10.	Synchronize Start	20
3.	TIMING	21
3.1.	Switching the TdC 8000 on	21
3.1.1.	First Heat	21
3.1.2.	Continue to Work in the First Heat after you Switch on	24
3.1.3.	Second Heat (next Heat)	25
3.2.	Keyboard Functions	28
3.2.1.	Start-Keyboard	28
3.2.2.	Finish-Keyboard	28
3.2.3.	Function-Keyboard	29
3.3.	Start-Mode	31
3.1.1.	Single Start	31
3.3.1.1.	Start Mode for the First Heat	31
3.3.1.2.	Start Mode for the Second Heat	32
3.1.2.	Group Start	33
3.1.3.	Mass Start	33
4.	SPECIAL FUNCTIONS	34
4.1.	Test - Checking the TdC 8000	34
4.2.	BLOCK - Deactivate the Impulse-Channels	34
4.2.1.	Blocking the Start	34
4.2.2.	Blocking the Finish	34
4.2.3.	Individual adjustment of the channels	35
4.3.	Editing of Times	36
4.3.1.	Editing of Start Times	36
4.3.1.1.	Clear Start Times	36
4.3.1.2.	Restoring a Cleared Start Time	36
4.3.1.3.	Changing Start Times	36
4.3.1.4.	Input Start Times (Start Intervals)	37
4.3.2.	Editing of Finish Times	38
4.3.2.1.	Clear Finish Times	38
4.3.2.2.	Restoring a Cleared Finish Time	38

4.3.2.3.	Changing Finish Times	38
4.3.2.4.	Editing Run times, Memory Times, and Intermediate Times	39
4.3.2.4.1.	Editing a Run time	39
4.3.2.4.2.	Editing a Memory Time	40
4.3.2.4.3.	Editing a Intermediate Time	41
4.4.	MEMO - Time Buffer for Mass-Finish-Arrivals	42
4.5.	CLASS. - Classement	44
4.5.1.	Classement in Heat 1	44
4.5.2.	Classement in Heat 2	49
4.5.3.	Race Points	49
4.6.	PRINT - Switching the Printer off or on	50
5.	MAIN MENU - GENERAL ADJUSTMENTS	50
6.	PROGRAMS	62
6.1.	Split	Program 1 63
6.2.	Sequential (not ready)	65
6.3.	Split Sequential	Program 3 66
6.4.	Parallel Slalom	70
6.4.1.	Parallel Diff. (Parallel Slalom with Finish-Difference-Time ...	Program 4 70
6.4.2.	Parallel Net	Program 5 74
6.5.	Dual Timer	Program 6 80
6.6.	Speed	Program 7 84
6.7.	Speed Skiing	Program 8 88
6.8.	TdC TEST	Program 9 90
7.	DESCRIPTION OF ADDITIONAL DEVICES	92
7.1.	Multi Channel MC18	92
7.2.	Opto Channel OC18	92
8.	TECHNICAL DATA	93
8.1.	Connection System	94
8.1.1.	Photocell jacks and extern supply	94
8.1.2.	Headset Jack (18)	94
8.1.3.	Speaker Jack (25)	94
8.1.4.	Display Board Jack (24)	94
8.1.5.	RS 232 / RS 485 (23)	95
8.1.6.	Display Board (28)	95
8.1.7.	Banana Socket for Channel 0 to 9 (27)	95
8.1.8.	Multi Channel (16)	95
8.2.	RS 232 Interface (16, 23)	96
8.2.1.	Checking the TdC8000 Adjustments through the RS 232 Interface	97
8.2.2.	Adjustment of the Main Menu through the RS 232 Interface	98
8.2.3.	Call Data through the RS 232 Interface	99
8.3.	RS 485 Interface (16, 23, 28)	103
8.4.	Display Board Interface (24)	104

1. DEVICE DESCRIPTION

The TdC 8000 is the descendent of the popular TdC 4000 used for over 14 years worldwide. Compared to the TdC 4000 it has a bigger memory and the software is much more flexible. An additional alphanumeric display shows whatever is important for the operator.

It has a memory capacity of about 18.000 times for a maximum of four races. The most modern processor 80C166 guarantees to work effective and fast. The new RS 485 interface holds open many feature uses for the TdC 8000.

The separated keyboard makes it possible to work with two persons on the TdC 8000 at the same time (e.g. one for start, one for finish)

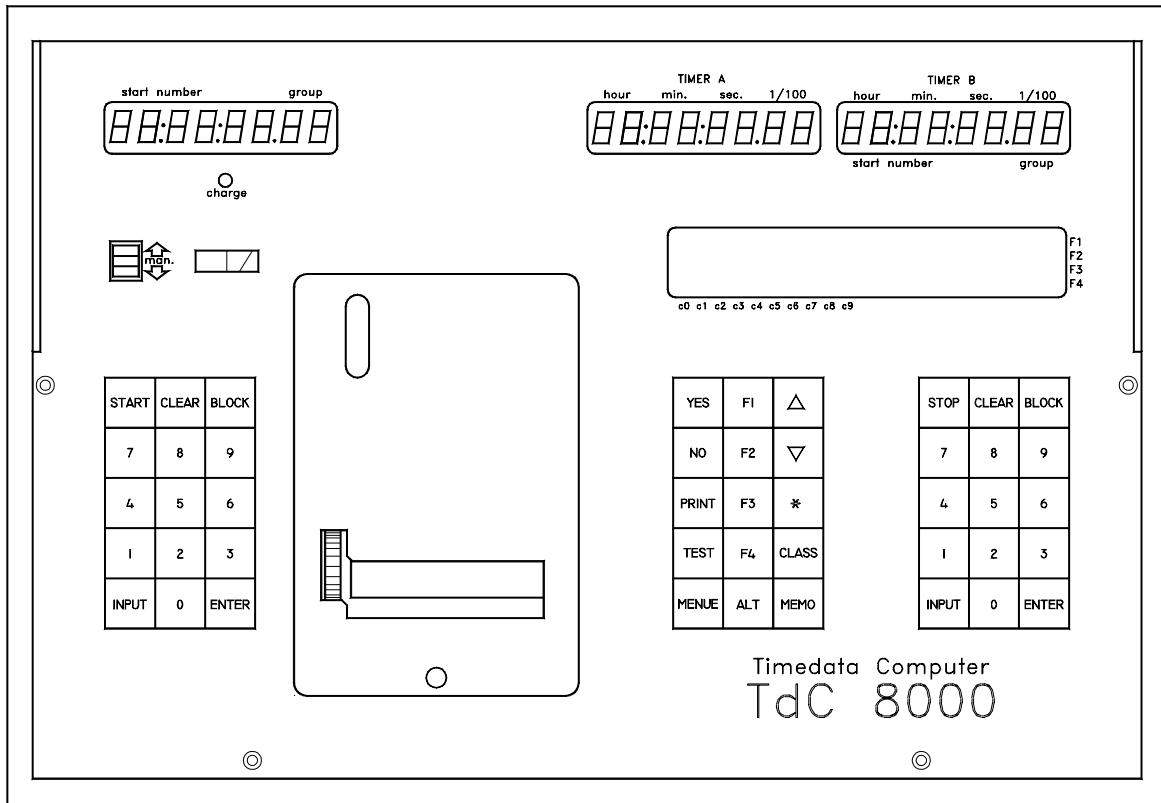

1.1. Standard Software:

Programm	Program Number	Page
Split	Program 1	63
Sequential	Program 2	in preparation
Split Sequ.	Program 3	66
Parallel Diff.	Program 4	70
Parallel Net	Program 5	74
Dual Timer	Program 6	80
Speed	Program 7	84
Speed Skiing	Program 8	88
TdC Test	Program 9	90

SPLIT: **Program 1**
 Program for timing with intermediate time. You can adjust the precision. You can make up to 256 heats. You have a start-channel (c0), a finish-channel (c1), and up to eight intermediate-channels (c2 to c9)

SPLIT SEQUENTIAL (SPLIT SEQU.): **Program 3**
 Program for timing with lap time and run time. You can adjust the precision. Previous to the race you must adjust the amount of laps. You can make up to 256 heats. You have a start-channel (c0), a finish-channel (c1), and up to eight intermediate-channels (c2 to c9)

PARALLEL SLALOM:

Parallel Diff: **Program 4**
 It shows the difference time between the two competitors and the winning course.

Parallel Net: **Program 5**
 It measures the net time of each course and the difference time between both competitors. It is also possible to get the total time in the second run for net- and difference time.

DUAL TIMER: **Program 6**
 Net timing with intermediate time on two courses with a maximum of one competitor on each course. The start can be parallel or separate for both courses.

SPEED: **Program 7**
 Program to measure the speed in either km/h, m/s or m.p.h.. You can adjust the measuring distance between 1 and 9999 m.

SPEED SKIING: **Program 8**
 Program to measure the speed and time for speed skiing.

TdC-TEST: **Program 9**
 Program to test the TdC 8000:

2. OPERATING

2.1. Power Supply:

The TdC 8000 has a built in rechargeable-NiCad-battery-pack (4.5 Ah).

Charge the NiCad-battery-pack with the NLG8 or a 12 Volt car-battery. The charging voltage must be between 11 and 16 Volts. To load the TdC 8000 you need to turn it on.

2.1.1. Net-Charging-Set NLG8:

With the net-charging-device NLG8 you can load the TdC 8000 direct form the mains:

- Plug NLG8 at the mains.
- Plug NLG8 at the socket „extern. supply“ (19) or „photocell (20, 21 or 22).
- Turn TdC 8000 on (switch 26).
- The read LED (3) must burn.

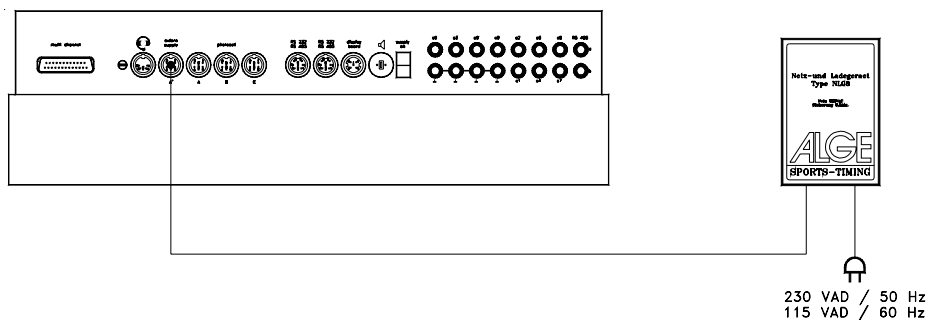

- o The TdC 8000 must be switched on during the charging process (internal charging electronic)
- o You can load the TdC 8000 also during the normal timing operation.
- o The charging process with the NLG8 need about 12 hours.
- o The no-load-voltage is about 15 VDC.
- o The charging voltage of the NLG8 is about 11.7 VDC

ALGE has two types of NLG8. One is with 230V/50Hz, the other with 115V/60 Hz. The voltage is printed on the NLG8 case. Please make sure that you use the NLG8 with the correct voltage for your mains.

Attention: You cannot load the TdC 8000 when switched off!

2.1.2. External Battery (12 V car battery):

You can use any 12 Volt battery with a capacity of 5 Ah to charge or supply the TdC 8000.

- Connect cable 005-02 at socket "extern supply" (19) of the TdC 8000.
- Connect clips that says (+) at the plus pole of the battery.
- Connect clips that says (-) at the minus pole of the battery.
- Red LED (3) of the TdC 8000 must burn.

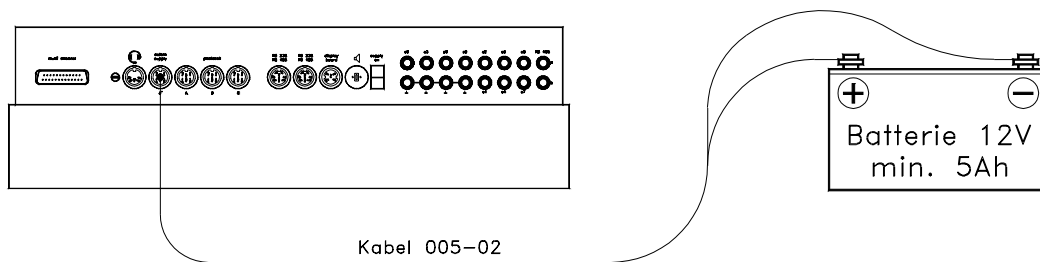

2.1.3. Working Time:

The voltage is shown on the info-display (6) if you press <TEST>. Further it shows the battery condition always on the meter (4). As long as you have the needle of the meter in the green section you can operate the TdC 8000.

2.1.4. Condition of the Rechargeable-Battery:

The TdC 8000 has six NiCad rechargeable batteries each with 1.2 V and 4.5 Ah. You can check the voltage by pressing <TEST>. It shows in the info-display the voltage. The TdC 8000 measures always the voltage of the batteries and shows a message as soon as they get empty.

Early warning: The info-display (6) shows: "Almost empty battery!"
 The voltage is 6,2 Volt
 You can continue to work until the voltage is 5,8 Volt. If possible plug a NLG8 or 12 Volt battery to charge (supply) the TdC 8000.

Turn off: The info-display (6) shows: "Empty battery!"
 The voltage is 5,8 Volt
 If the voltage is 5.8 Volt it switches the TdC 8000 in a power down mode. This is necessary to save the memory. As soon as you supply the TdC 8000 with the NLG8 or a 12 Volt Battery you can continue to work. The machine is still synchronized.

2.2. Printer:

When you switch TdC 8000 on it activates the printer automatically. After you selected the program you can make the following adjustments for the printer:

Print-Mode: The printer prints all data. The printer is automatically in this mode, when you switch the TdC 8000 on.

Buffer-Mode: All data for the printer are stored in the buffer. This mode you use e.g. to change the paper.

- Printer is in Print-Mode
- Press <PRINT>
- Printer is now in the Buffer-Mode
- Press <PRINT>
- Printer is again in the printing mode. It prints now all data collected during the buffer mode.

Printer Off: The printer is off and all data for the printer are lost.

- Printer is in Print-Mode
- Press <ALT> and <PRINT> at the same time
- Printer is switched off
- Press <ALT> and <PRINT> at the same time
- Printer is in Print-Mode

- o **Paper Check**
 - Push cover release button (11).
 - Remove the cover.
 - Check the paper.

A black strip will become visible on the edge of paper, when the paper roll is about to run out.

- o **Changing the Paper:**

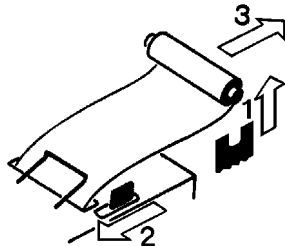

- Push cover release button (11) .
- Remove the cover.
- Remove the rest of the paper from the holder.
- Press the black lever forward and pull the paper out.

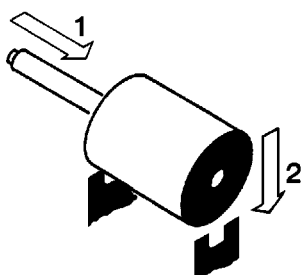

- Put the axle into the paper holder.
- Put the now roll on the paper holder.

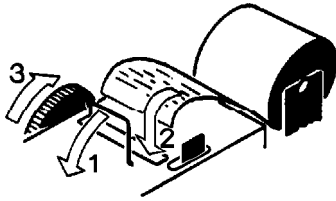

- Insert the beginning of the paper into the paper feed of the printer. Make sure it is cleanly out.
- If necessary correct the paper path through pressing the black lever forward and adjusting the paper manually.
- Put the cover back and press the button until they stay in the lower position.

Attention: Please take care that the paper goes through the paper slotted hole of the cover when you put the cover back on.

Clearing Jammed Paper:

- Press the black lever forward and pull back the remaining paper.
- Remove the serrated cutter by holding the black lever forward and sliding the cutter towards the lever and lifting upwards.
- Pull the print head back with your fingernail and remove any stuck paper with tweezers or small needlenose pliers.
- If the paper has jammed under the roller it will be necessary to remove it by sliding a piece of 35 mm film through the paper path and rocking it to and fro until the stuck paper is expelled. Use a piece of film about 20 cm long to have something to hold onto.

The printer is a very rugged device but needs regular maintenance for a long service life. Call your ALGE agent if you have further questions.

Printer-Paper:

Electrosensitive paper 60 mm width, 40 mm diameter with about 25 m paper length (about 6000 lines). The electrosensitive paper is available at your ALGE representative.

A black strip will become visible on the edge of paper, when a paper roll is about to run out.

Attention: Do not pull on the paper when printing. Press the black lever forward and pull the paper carefully out, if the paper is repressed.

The printer-paper has to stay dry!

2.3. How to Connect other Devices with the TdC 8000:

o Net-Charging-Set NLG8:

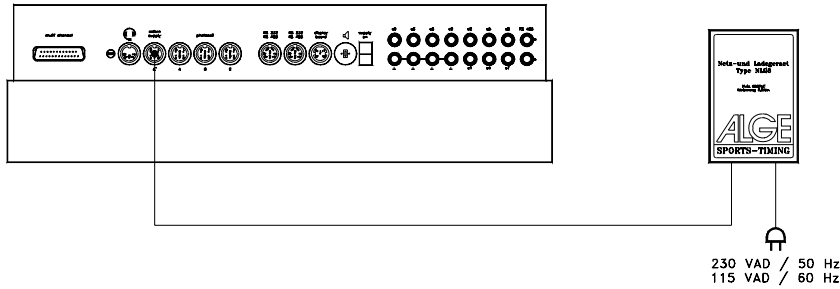

o External 12 Volt Battery:

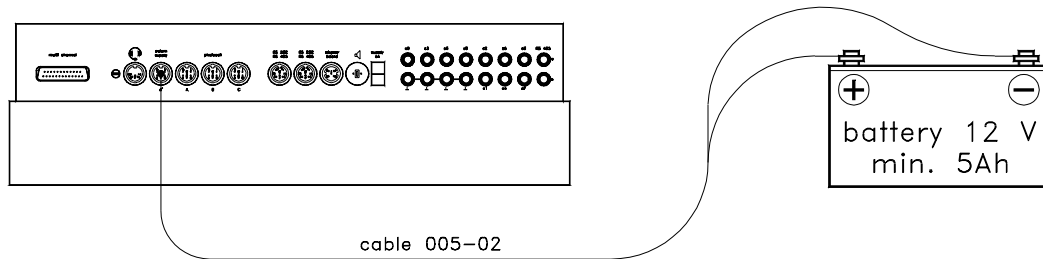

o Startgate STSc with a Headset:

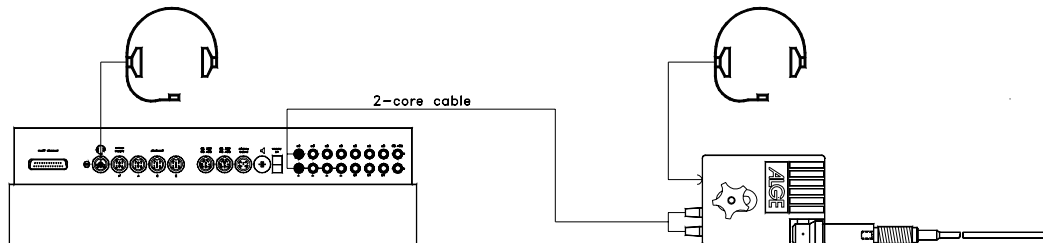

o Photocell RLS1c:

- Finish Photocell:

If you have one photocell for the finish you must use socket (19). If you make a race with three different start and finish, use socket (19) for finish 1, socket (20) for finish 2 and socket (21) for finish 3.

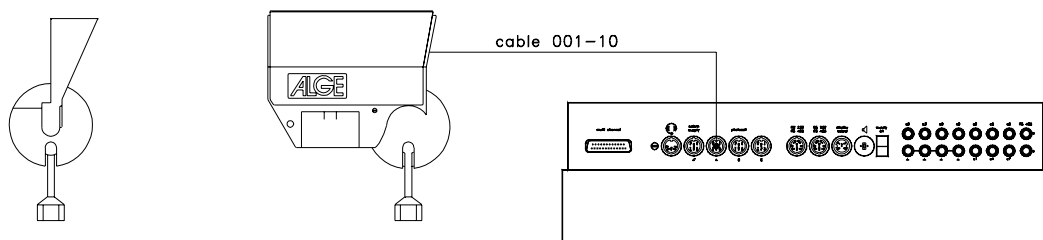

- **Intermediate time (supply from the TdC 8000):**

The cable you have to use depends on the program you use. For program SPLIT you can use cable 003 (up to 100 m cable length).

- **Intermediate time (2-wire cable):**

For each timing channel you have a banana socket. If you connect a photocell with the banana socket you need an external supply for the photocell (battery into the photocell) Plug cable 027-02 at the photocell. From this cable you can go to the TdC 8000 with a 2-wire cable (e.g. cable real KT 500 or KT 300).

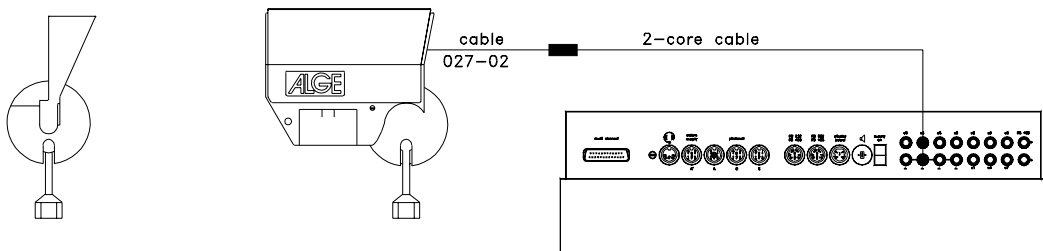

o **Display Board GAZ4:**

For distances over 10 Meter you can use any 2-wire cable with banana plugs (e.g. cable real KT 500 or KT 300).

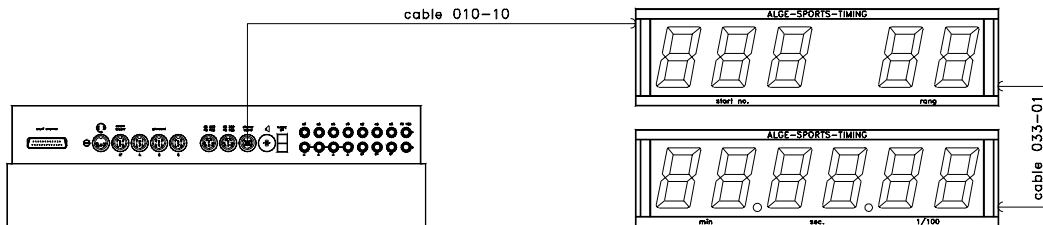

o **Startmicrophone SM7 with Speech Amplifier SV4/SM:**

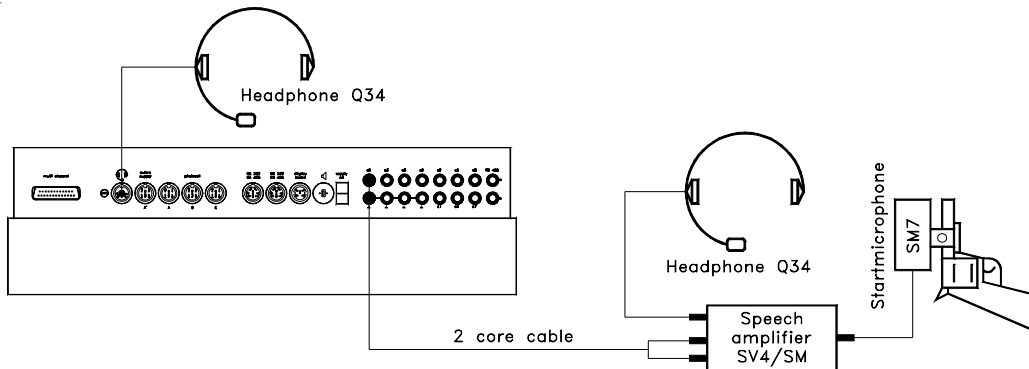

o Photocell Adaptor LA4:

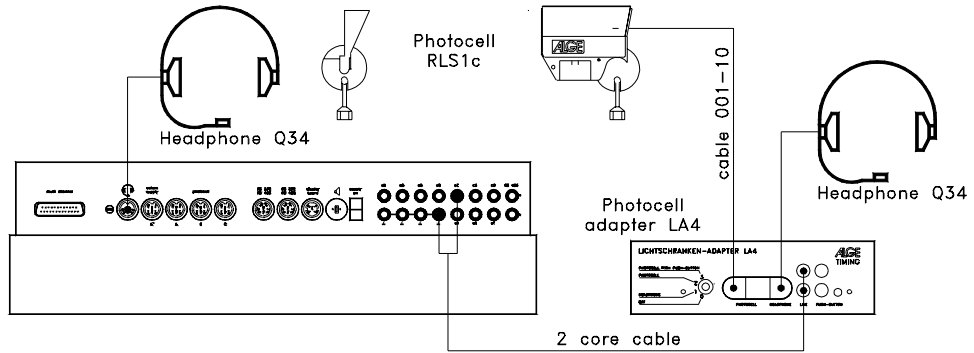

o Handswitch:

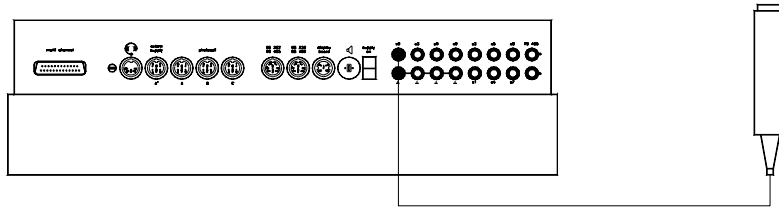

o Speaker DL:

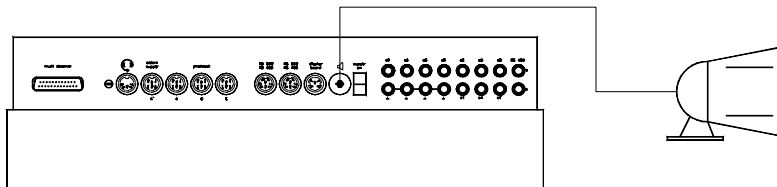

o Personal Computer:

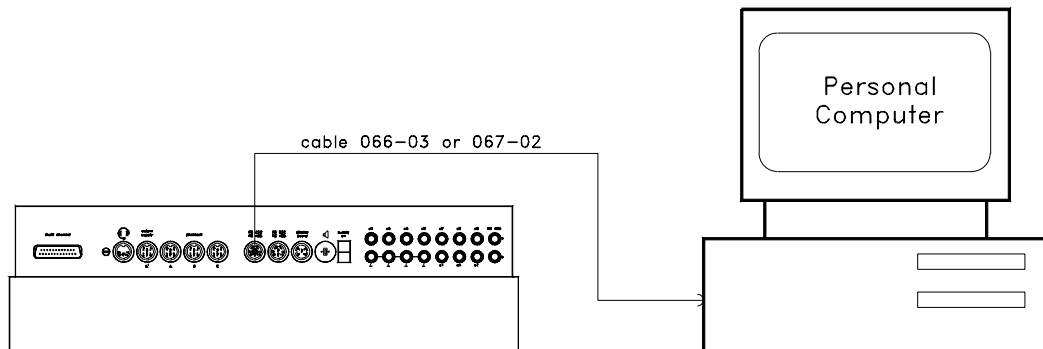

2.4. Memory:

The memory function in the TdC 8000 is designed to allow you to have up to four races with the same number range. Therefore you could have a race for men with start numbers from 1 to 100 and a race for women with the same start numbers. If you have a race with different start numbers for each category, the groups function should be used. Make sure that the organizing committee clearly lists the number range of the groups and how they should be run. The TdC 8000 is designed to allow the orderly transfer of time keeping from one race to another. It is not designed to allow the switching of races on the spur of the moment.

The TdC 8000 has memory which will store approximately 18,000 times. Per race you can store a maximum of 9,000 times. Together race 1 and 2 have a capacity to store 9,000 times as well as race 3 and 4. For instance, if you have stored 1000 times in race 1 already you have 8000 times available in race 2.

For each race a maximum of 256 heats (runs) can be stored. You can clear the memory each time you turn the TdC 8000 on, or if you change a race in the main menu.

For the actual heat the TdC 8000 always stores the start time (time of day), finish time (time of day), and run time, if you use the difference time mode. For the previous heat it always stores the memory time (total time from all previous heats).

Times stored in the first heat:

- start time (difference time)
- finish time (difference time)
- intermediate time (each intermediate time)
- run time

Times stored in the second (third, etc.) heat:

- memory time
- start time (difference time)
- finish time (difference time)
- intermediate time (each intermediate time)
- run time
- total time

2.4.1. Memory Organisation:

There is a limited amount of memory capacity for each race:

- Race 1:** about 8,600 times, if race 2 has no data stored
- Race 2:** about 8,600 times, if race 1 has no data stored
- Race 3:** about 8,600 times, if race 4 has no data stored
- Race 4:** about 8,600 times, if race 3 has no data stored

2.4.2. Clear Memory:

After turning the TdC 8000 on (switch 26) you have to select the program. Then you are asked if you want to clear the memory. The info-display (6) shows the following message:

Clear race:	8350/ 253 R1	F1	You can clear each race individually with the <F> keys.
	0/ 253 R2	F2	
	651/ 7009 R3	F3	
Continue: ENTER	943/ 7009 R4	F4	

By pressing the <F> key you select the race that you want to clear. You can select different races at the same time. It clears the memory when you press the <ENTER> key of the finish keyboard (15).

E.g.: If you clear race 1 and 3 it shows the following figures on the info-display (6):

```

Clear race:                8350/ 253 R1< F1
                          0/ 253 R2  F2
                          651/7009 R3< F3
Continue: ENTER           943/7009 R4  F4
  
```

If you press <ENTER> without pressing an <F> key it will not clear the memory.

2.5. Select a Race:

After clearing the memory you have to select the race that you want to use. You can keep a maximum of four races at the same time in the memory. Each race is completely independent. This means that for each race you can use the same bib numbers from 1 to 9999 and you can make up to 256 heats.

```

Select race:              7012/ 1591 R1< F1
                          0/ 1591 R2  F2
                          651/ 7009 R3  F3
Continue: ENTER           943/ 7009 R4  F4
  
```

Two numbers are shown for each race. The first number shows how much memory you have used, and the second how much memory you have available. For a cleared race it shows zero as first number.

When "select race" is displayed the cursor will be placed on the previous race. If you want to select that race again press <ENTER>.

If you want to select a different race you can select with key <F1>, <F2>, <F3>, or <F4>.

The race selected is always marked with an arrow.

Memory was not cleared:

If you select a race that is not cleared it will show the following message in the info-display (6):

```

Select Heat:              SAME (1) < F1  (1) means first heat
                          NEXT (2)  F2  (2) means second heat
Continue: ENTER
  
```

If you select the same heat, you can continue to work in that same heat as you worked before. If you select the next heat, then a new heat is started.

If you select a new heat:

- All valid run times (or total times) will be stored as memory time
- All other times will be cleared (e.g. start-, finish-, intermediate time)

2.6. Precision:

You have to select the degree of precision that you want for the run time, intermediate time, and total time. The Timer itself always uses 1/10,000 resolution, which is especially important if you use the difference timing mode.

Use the <F> key to select. The cursor will always be on the position used previously.

Select precision:	1 s	F1
	1/10 s	F2
	1/100 s<	F3
	1/1000 s	F4

2.7. Timing Modes:

We use two different timing modes: difference timing and absolute timing. You must select the timing mode before you start a race:

Select timing:	ABSOLUTE	F1	select with <F1>
	DIFFERENCE<	F2	select with <F2>

Continue: ENTER

Absolute:

Time starts form 0:00.00
 The run time (and intermediate times) are stored for each competitor.
 This mode should be used for races with mass start.

Advantage: For each competitor only one memory place during the first heat (if you have no intermediate times)

Disadvantage: If you do not have a mass start, it will be impossible to make time corrections.

Selection: Press <F1> and <ENTER>

Difference:

The time of day is stored for each start- and finish impulse. Therefore you have to input the time of day first. From the difference between finish time and start time it calculates the run time. This mode should be used for single start and group start races.

Advantage: You can correct times.

Disadvantage: For each competitor at least three memory places are needed (start time, finish time, run time).

Selection: Press <F2 > and <ENTER>

2.8. Input of Groups:

You can input up to 99 groups. A group must consist out of competitors with continues start numbers. If you input groups it shows always the rank within the group, and you can make a group-start and group-classement.

Input groups?	YES	F1
	NO<	F2

Continue: ENTER

If you do not want to input a Group, then press <NO> or <F2> and <ENTER>. If you want to input a Group, then press <YES> or <F1> and <ENTER>.

GROUPS:	Gr	1:	1 >	<u>0</u>
---------	----	----	-----	----------

Save with: ENTER

Input the last start number of each group. The TdC selects automatically as first start number of the next group the next higher start number.

GROUPS:	Gr	1:	1 >	60	First group from StNo. 1 to 60
	Gr	2:	61 >	90	Second group from StNo. 61 to 90
	Gr	3:	91 >	120	Third group from StNo. 91 to 120
Save with: ENTER	Gr	4:	121 >	<u>0</u>	No input yet

Attention: You should always input the groups, that you have some empty start numbers in every group. This start numbers you can use in case of late entries.

2.9. Test-Function - Checking the TdC 8000:

When you press <TEST> the Info-Display (6) shows the following:

C0 =	4.9V	battery	=	7.3V					
C3 =	4.9V	photocell	=	4.9V					
C6 =	4.9V	extender	=	0.00A					
# # # # #	# # # # #								
c0	c1	c2	c3	c4	c5	c6	c7	c8	c9

The Test-Function shows the condition of the device. The condition of all ten channels are monitored (line 4). If one channel blinks, it means that it has a short-circuit. For channel c0, c3 and c6 the voltage is shown.

In addition it shows the voltage of the NiCad battery, the photocell, and the current for the extender.

Channel c0, c3, and c6 should normally have about 5 V (open). When an impulse is reached the voltage must go down to 0 V.

When fully loaded the battery has about 7.4 V. The empty battery has a voltage of about 5.5 V. At this voltage the device switches off. A battery warning appears on the info-display (6) when the power is 6.2 V or lower.

The stabilized voltage "photocell" supplies the photocells and must be about 5 V.

The current for extender-devices must be less than 1 A (interface RS 485 (23)). If the current reaches 1 A it switches the supply for the extender off.

Line Test - Checking the Start and Finish Line:

Checking a 1 pair cable which is connected at banana socket c0, c3, or c6.

- Switch TdC 8000 on (switch 26)
- Select the program
- Make the program ready for timing
- press <TEST> (keep it pressed)
- The info-display (6) shows the TdC 8000 measurements
- Measurement of channel c0, c3 and c6 is important for the line test

o Short-Circuit-Test:

- Cable is open on the start side
- Press <TEST> (press key until you finish the test)
- The voltage of the open channel (c0 , c3, or c6) must be about 4.9 Volt

o Resistance-Test:

- Short circuit the pair on the start side (press banana plug together)
- Press <TEST> (press key until you finish the test)
- The voltage with shorted channel (c0, c3, or c6) must be between 0 and 0.9 Volt. If the voltage is higher than 0.9 V the resistance of the cable is too high (maximum 2000 Ω loop resistance).

The line test meter is only for quick reference. Please use a multimeter set on Ohms for accurate testing of your wiring. Remember that resistance on the line will change due to weather conditions. Always check the condition of splices, especially in extremely cold temperatures. Scotchlocks and AMP locks have a bad habit of opening due to the expansion rate differences between the copper wire and the steel splicing plate. You should use the older "White Bean" connectors if there is a chance that temperatures will fall to below -10 F (-15°C).

Most of the problems with timing installations are due to wiring on the course. Please take the time to review your wiring early in the season. Bad splices and connections will only get worse as time goes on and they are a lot easier to deal with in the Fall before the pedestals get covered with snow.

Please call your ALGE agent for assistance with wiring. They are able to consult with you on proper wiring plans and are usually available to travel to your site for more detailed work at reasonable expense.

Needle of meter (3) swings:

The needle of the meter starts to swing as soon as the photocell is out of line. Please check the set

up of the photocell. A swinging needle could also be coffered during a very long timing impulse or through a short-cut of the cable.

2.10. Synchronize Start:

Synchronization between TdC 8000 and other timing devices is possible. You synchronize the TdC 8000 after you adjust the time before you start the timing.

Connect other timers through banana socket of channel c0 of the TdC 8000 with a 1 pair cable (or cable 004 at socket 19 or 20).

Time: 10:15:23	OK<	F1	time on display is correct
Date: 96-02-28	WRONG	F2	time on display is not correct

Continue: ENTER

There are two ways to make the synchronization:

- Synchronization from the internal clock
- Manual synchronization

Synchronization from the internal clock:

- Press <F1>
- Press <ENTER>
- The info-display (6) shows:

Time: 10:15:45
Date: 96-02-28

Synchronize: on minute change

- At the next sharp minute the TdC 8000 gives the synchronise impulse through channel c0.
- At the synchronization it gives a beep form the TdC 8000.
- The time of day disappears in the info-display (6).
- The TdC 8000 is ready for timing.

Manual synchronization:

- Press <F2>
- Press <ENTER>
- The info-display (6) shows:

Time: 10:15:34
Date: 96-01-16

Save with: ENTER

- Input (correct) the time of day with the finish keyboard (15) and confirm with <ENTER>.
- Input (correct) the date with the finish keyboard (15) and confirm with <ENTER>.

Time: 10:16:00
Date: 96-03-28

Synchronize: START-key / channel C0

- Start the timers by pressing the <START> key or through an external impulse of channel c0.

- The TdC 8000 is ready for timing.

3. TIMING

3.1. Switching the TdC 8000 on:

3.1.1. First Heat:

- Turn TdC 8000 with switch (26) on.

- It shows you on the info-display the following:

```

ALGE TIMING
TdC 8000
  
```

company name
 name of device

ENG V96.C2

language and software version

number

- After some seconds it shows the program that was used the last time

```

Program 1: SPLIT          V 96.C2
  
```

program name and version number

Select: YES/NO or program number

possible selections

- Select the program with <YES> or <ENTER>. If you want another program, you can input direct the program number, or use <N0> or the cursor until you have the correct program on the screen.

- The info-display (6) shows the used memory (see point 2.4 on page 15):

```

Clear race:              1345/ 7258 R1  F1
                        0/ 7258 R2  F2
                        1250/ 6819 R3  F3
Continue: ENTER          534/ 6819 R4  F4
  
```

- It is possible to store four different races (R1, R2, R3 and R4). The info-display (6) shows how many memory is used (first number) and how many is free (second number)
- Press <F1>, <F2>, <F3> or <F4> to mark the races that you want to clear (it shows a arrow in the display at the end of the line).
- Press <ENTER> to clear the races.

- You have to select now the race:

```

Select race:              0/ 8603 R1< F1
                        0/ 8603 R2  F2
                        1250/ 6819 R3  F3
  
```

Continue: ENTER 534/ 6819 R4 F4

- Select race with <F1>, <F2>, <F3> or <F4> and confirm with <ENTER>
- If you select a cleared race you have to select the timing precision:

Select precision:	1 s	F1	Precision: seconds
	1/10 s	F2	Precision: 1/10 seconds
	1/100 s	F3	Precision: 1/100 seconds
Continue: ENTER	1/1000 s	F4	Precision: 1/1000 seconds

- The precision is only for calculated times (run time, intermediate time, etc.), but not for the time of day.
- Select the precision with <F1>, <F2>, <F3> or <F4>. It will pre-select automatically the last precision that you used.
- Confirm the precision with <ENTER>.

- After the precision you have to select the timing mode:

Select timing:	ABSOLUTE	F1	Timing without time of day
	DIFFERENCE	F2	Timing with time of day

Continue: ENTER

- Select the timing mode with <F1> or <F2> (see point 2.7 on page 17).
- Confirm the timing mode with <ENTER>.

- After the timing mode you have to select the start mode:

Select start mode:	SINGLE START	F1	each competitor starts separate
	GROUP START	F2	within the group is a mass start
	MASS START	F3	all competitors start together

Continue: ENTER

- Select with <F1>, <F2> or <F3> the start mode (see point 3.3 on page 31).
- Confirm the start mode with <ENTER>

- After the start mode you have to select if you want to use groups:

Input groups?	YES	F1
	NO	F2

Continue: ENTER

- If you want to use groups (ranking within the group) press <YES> or <F1>.
- If you want no groups (ranking of all competitors) press <NO> or <F2>.

- If you input groups the info-display (6) shows the following:

GROUPS:	Gr 1:	1 >	50	Input always the last bib number of a group. If you want to input this tree groups, press for the fourth group two times
	Gr 2:	51 >	100	
	Gr 3:	101 >	230	
Save with: ENTER	Gr 4:	231 >	0	

3.1.2. Continue to Work in the First Heat after you Switch on:

- The process to switch the device on is as described for the first heat.
- Since you want to continue a race, it is not allowed to clear the memory.

- Select the correct race.

- The info-display (6) shows:

Select heat:	SAME (1) F1	The number stands for 1st heat
	NEXT (2) < F2	The number stands for 2nd heat

Continue: ENTER

- Press <F1> to select the same heat.
- Press <ENTER> to confirm the selection
- You have to synchronize the clock again or you take the internal time of the TdC 8000.
- The timer is ready.

3.1.3. Second Heat (Next Heat):

You can make up to 256 heats. For the heat(s) before it stores always a memory time (total time). There are two possibilities to get into the second heat:

- In the main menu you can change the heat (see page 58)
- Turn the TdC-8000 off and again on.

If you use the time of day it will print you the following results for each competitor:

0012	ST	10:07:04.640	Start time (time of day)
	FT	10:08:35.150	Finish time (time of day)
	RT	1:30.50	Run time
	MT	1:32.38	Memory time
	TT	3:02.88	Total time

Adjust in the main menu (menu 7), if you want the time started from zero, or from the total time of the previous heat (see page 53 - running time).

When a competitor finish it will show in the display (7) first either the run time, then the total time, or first the total time, then the run time, and again the total time. The display time you set in the main menu in point 4 and 5 (see page 52 - display time1 and 2). It shows each time for the duration of the display times.

Change Heat in Main Menu:

Advantage: You do not have to synchronize the device again. All adjustments stay as before.

Disadvantage: If you have a long break between the heats you have the device always running. This means, as longer as the race and the break, as more time difference you get between synchronized devices. If you have no external supply it will empty also the battery in the break between the heats.

How can you Change the Heat in the Main Menu:

- Press <ALT> and <MENU> at the same time.

- Select with cursor-key into menu 24 "CHANGE HEAT":

```
Menu 24: CHANGE HEAT
```

- Press <YES>

```
Select: YES/NO or menu number: 24
```

```
Select Heat::          SAME (1) < F1  continue in same heat
                       NEXT (2)  F2  continue in the next heat
```

Continue: ENTER

- With <F2> and then <ENTER> you select the next heat. The number in the brackets shows always the heat number (2 = second heat).

```

Start order:                START NUMBER< F1
                           BIBO WITHOUT GROUPS F2
                           BIBO WITH GROUPS  F3
  
```

Continue: ENTER

- Select with <F1>, <F2> or <F3> the start mode and confirm it with <ENTER>:
 - *Start number:* The start order is after the bib numbers. With the switch (1) you can select it you want to count up, manual or down.
 - *Bibo without groups:* All competitors start after the BIBO rule. You have to input the amount of competitors that you want to reverse and confirm it with <ENTER>.
 - *Bibo with groups:* In each group the competitors start after the BIBO rule. You have to input the amount of competitors that you want to reverse for each group and confirm it with <ENTER>.
- The TdC 8000 is ready for the new heat.

Changing a Heat by Turning the TdC 8000 off:

Advantage: If you have a long break it does not use battery power if you switch it off. If you have the TdC 8000 synchronized with other devices it is exactly synchronized for the second heat again.

Disadvantage: You have to synchronize the TdC 8000 again for the new heat (with Startclock, backup timer, etc.)

You have to go through the same start procedure for the second heat as for the first heat.

If you change from one heat to the next heat you have to switch the TdC 8000 with switch (26) off and again on. Be careful that you do not clear the memory of the first heat.

- Switch the TdC 8000 with switch (26) on and select the program as in the previous heat.
- Do not clear the memory of the race.

- Select the correct race
- The info-display (6) shows:

```

Select Heat::                SAME (1)< F1  continue in same heat
                           NEXT (2)  F2  continue in the next heat
  
```

Continue: ENTER

- With <F2> and then <ENTER> you select the next heat. The number in the brackets shows always the heat number (2 = second heat).

```

Start order:                START NUMBER< F1
  
```

BIBO WITHOUT GROUPS F2
BIBO WITH GROUPS F3

Continue: ENTER

- Select with <F1>, <F2> or <F3> the start mode and confirm it with <ENTER>:
 - *Start number:* The start order is after the bib numbers. With the switch (1) you can select it you want to count up, manual or down.
 - *Bibo without groups:* All competitors start after the BIBO rule. You have to input the amount of competitors that you want to reverse and confirm it with <ENTER>.
 - *Bibo with groups:* In each group the competitors start after the BIBO rule. You have to input the amount of competitors that you want to reverse for each group and confirm it with <ENTER>.

- Synchronize of the TdC 8000:

Time: 10:15:23
Date: 96-02-28

OK< F1
WRONG F2

Continue: ENTER

- Synchronize TdC with other timing devices (see page 20, chapter 2.10)
- The TdC 8000 is ready for the new heat.

3.2. Keyboard Functions:

The keyboard of the TdC 8000 has three different blocks: - Start-keyboard (9)
- Finish-keyboard (15)
- Function-keyboard (14)

Because of the separated keyboard blocks it is possible for two persons to work on the TdC 8000 at the same time. One person can manage the start, the other the finish (and intermediate times). The display (2) works always together with the start-keyboard (9). The display (7) and (8) works always with the finish-keyboard (15).

The function-keyboard (14) works together with the start-keyboard or finish-keyboard. It shows the informations on the info-display (6)



3.2.1. Start-Keyboard:



Manual start-impulse (SZM on printer, COM on RS232), precision only 1/100

It clears the start time of the start number shown on display (2). (FALSE START)
If you press <ALT> and <CLEAR> together, it restores the cleared time again.



As long as you press <BLOCK> it will print all incoming start impulses (channel 0) as not valid. The time is marked on the first digit with a ?.

As long as you press <ALT> and <BLOCK> together, it ignores incoming start impulses (channel 0; see page 34)



to input the start number at the start. It shows the start number on the start-display (2).



To edit the start time of the start number in the start display (2).
If you press <MENU> and <INPUT> at the same time you get to start time input mode. You can input times individual or in intervals, etc.

Each start number that you input you must confirm with <ENTER>. Depending on the switch position of switch (1) the start number counts automatically up, down, or stays.



3.2.2. Finish-Keyboard:



Manual stop-impulse (ZZM on printer, C1M on RS232), precision only 1/100



It clears the finish time of the start number shown on display (2). (FALSE FINISH)
If you press <ALT> and <CLEAR> together, it restores the cleared time again.



As long as you press <BLOCK> it will print all incoming finish impulses (channel 1) as not valid. The time is marked on the first digit with a ?. The time does not stop.



As long as you press <ALT> and <BLOCK> together, it ignores incoming finish impulses (channel 1).



to input the start number at the finish (intermediate time). It shows the start number on the finish-display (8).
To edit the finish time of the start number in the finish display (8).
If you press <MENU> and <INPUT> at the same time you can change the run time, memory time or intermediate time.

Each start number that you input, you must confirm with <ENTER>.

Increment start number: - up: press <ENTER>
- down: press <ALT> and <ENTER> together



3.2.3. Function-Keyboard (14):



To confirm a YES/NO question

If you do not confirm a YES/NO question

If you press <PRINT> it switches the printer into the buffer mode. This means that all information for the printer will be stored in the buffer. If you press again <PRINT> it will print all the data from the buffer. This function is mainly to use when you change the paper.



If you press <ALT> and <PRINT> together it switches the printer off. All printer information is now lost. If you press <PRINT> or <ALT> and <PRINT> again it switches the printer on.



If you press <MENU> and <PRINT> together it prints all adjustments of the main menu.



To test the TdC 8000 (see chapter 2.9 on page 18).



Key has no function yet.



To print the Classement (see chapter 4.5 on page 44).



Cursor-key up

Cursor-key down



It goes always together with another key. You have to press first <ALT> and then the second key. Do not release <ALT> before you pressed the second key. <ALT> has a function together with <CLEAR>, <BLOCK>, <MENU>, and <PRINT>.



It goes always together with another key. You have to press first <MENU> and then the second key. Do not release <MENU> before you pressed the second key. <MENU> has a function with <ALT>, <INPUT>, <PRINT>, and <BLOCK>.



Function key 1: To select in a menu of the info-display (6) when the text is placed at the right side in line 1.



Function key 2: To select in a menu of the info-display (6) when the text is placed at the right side in line 2.



Function key 3: To select in a menu of the info-display (6) when the text is placed at



the right side in line 3.

Function key 4: To select in a menu of the info-display (6) when the text is placed at the right side in line 4.

Memory for mass arrivals at the finish or intermediate time (see chapter 4.4 on page 42).

3.3. Start-Mode:

You can choose between three different start-modes:

- **Single Start:** each competitor starts separate
- **Group Start:** all competitors within a group start together
- **Mass Start:** all competitors start together

With the switch (1) you control the start automatic for singles start and group start. This switch has three positions. It shows the switch position on the start-display (2).

- *upper position:* after each start it changes the start number to the next free higher start number.
- *middle position:* manual mode, the start number stays until you change it with the keyboard.
- *lower position:* after each start it changes the start number to the next free lower start number.

3.3.1. Single Start:

Each competitor has a separate start time. In this mode you can select the output mode of the info-display (6) (see page 53 Menu 7: INFO-DISPLAY).

3.3.1.1. Start Mode for the First Heat:

If the start number increases e.g. from 1, to 2, to 3, to 4, etc. after each start you can use the automatic start mode (switch 2 in upper position).

Start number goes up automatically after each start

- Switch (1) in upper position (it shows the switch position in the start display 2).
- It shows 1 as start number in the start display (2).
- After the start of number 1 it increases the start number automatically to 2.
- After each further start it increases the start number again (automatically to the next start number that is not started yet).
- A manual correction of the start number is possible at any time (keyboard 9). If you press <ENTER> it increases the start number to the next start number that is not started yet.
- The display (2) shows for a start number with a start time a "u" in the display (u stands for used).

Start number goes down automatically after each start:

- Switch (1) in lower position (it shows the switch position in the start display 2).
- It shows 1 as start number in the start display (2).
- Input with keyboard (9) the start number that starts first (e.g. 48) and confirm it with <ENTER>.
- After the start of number 48 it decreases the start number automatically to 47.
- After each further start it decreases the start number again (automatically to the next lower start

- number that is not started yet).
- A manual correction of the start number is possible at any time (keyboard 9). If you press <ENTER> it increases the start number to the next start number that is not started yet.
- The display (2) shows for a start number with a start time a "u" in the display (stands for used).

Manual start input:

- Switch (1) in middle position (it shows the switch position in the start display 2).
- It shows 1 as start number in the start display (2).
- Input with keyboard (9) the start number that starts (e.g. 12) and confirm it with <ENTER>.
- After the start it shows a "u" in the display (2) . It stands for used and mans that this start number is already started.
- Input with keyboard (9) the next start number that starts (e.g. 25) and confirm it with <ENTER>.
- After the start it shows a "u" in the display (2) . It stands for used and mans that this start number is already started.

3.3.1.2. Start Mode for the Second Heat:

The start procedure for the third, fourth, etc. heat works like in the second heat. The switch (1) has the same function as in the first heat. If you use the BIBO mode for the second heat it is important that you have the upper position selected.

For the second heat you have the following text on the info-display (6):

```

Start order:          START NUMBER< F1
                    [F1]  BIBO WITHOUT GROUPS F2
                    BIBO WITH GROUPS F3
Continue: ENTER      F4
  
```

Select the start order with <F1>, <F2> or <F3>.



o Start number:

The start order works like for the first heat, depending on the switch position of switch (1).

o Bibo with groups:

The bibo rule is used in alpine skiing. Bibo does the following:
For races with two or more heats it takes the as start order the ranking of the first (previous) heat, except of the first places as start order for the 2nd heat. You have to input how man places you have to reverse. If you input e.g. 15 it does the following.

- | | |
|----------------------|-----------------------|
| - rank 15 starts 1st | - rank 1 starts 15th |
| - rank 14 starts 2nd | - rank 16 starts 16th |
| - rank 13 starts 3rd | - rank 17 starts 17th |
| - etc.. | - etc. |

The TdC 8000 asks you how many competitors you have to invert. The TdC requests the FIS value of 15.

```

Invert:   15
                    Amount of inverted
                    competitors
  
```

Save with:  ENTER

Confirm your selection
with <ENTER>

Attention: Switch (1) must be in the upper position!

o Bibo with groups:

You have to input the amount of competitors to invert for each group. For the Bibo rule it takes the classement of the previous heat.

e.g.: You have a race with three groups:

INVERT:	Gr 1:	15	Input the amount of competitors that you want to invert and with <ENTER>.
	Gr 2:	15	
	Gr 3:	15	

Save with: ENTER

Attention: "Bibo with groups" works only in the second heat if you worked in the first heat with groups. The switch (1) must be in the upper position!

3.3.2. Group Start:

Within a group they start with the same start time. If you use the group start, you should input groups. It is possible to input the groups during the switch on procedure or in the main menu (Menu 22: Groups; page 57).

If you do not input a group it will start all numbers (from 1 to 9999) with the first start impulse.

You can not use <CLEAR> of the start-keyboard (9) to clear a start time (it stores only one time for a group). To change the start time of a group, use <INPUT> of the start keyboard (9).

3.3.3. Mass Start:

All competitors from 1 to 9999 start with the same start time.

If you want to make a race with many competitors and a mass start, we recommend to use ABSOLUTE TIMING. This mode gives stores per competitor only the run time (if you have no intermediate time).

You can not use <CLEAR> of the start-keyboard (9) to clear a start time (it stores only one start time for all competitors). To change the start time of the competitor field, use <INPUT> of the start keyboard (9).

4. SPECIAL FUNCTIONS



4.1. TEST - Checking the TdC 8000:



see chapter 2.9 on page 18

4.2. BLOCK - Deactivate the Impulse-Channels:

You can deactivate each impulse channel (c0 to c9). There are two possibilities to deactivate the channels.

- o The TdC 8000 ignores each impulse of a selected channel (channel off)
- o The TdC 8000 marks each impulse of a selected channel (with ?). The time does not start or stop on the display and display board.



Channel 0 (start) and 1 (finish) you can deactivate direct.

4.2.1. Blocking the Start:

- All start impulses (c0) are not valid and the time of day is marked with a ? as long as you press <BLOCK> of the start-keyboard (9).

Printer: ?0043 ST 10:34:13.384

Display Board: no output

RS 232: ?0043 C0 10:34:13.384 (CR)

- As long as you press <ALT> and <BLOCK> of the start-keyboard (9) together, the TdC 8000 will ignore all start impulses (channel 0). The TdC 8000 does not store or output this time.



If you block the start impulse it will not start the clock.

4.2.2. Blocking the finish:

- All finish impulses (c1) are not valid and the time of day is marked with a ? as long as you press <BLOCK> of the finish-keyboard (15). It does not stop the clock and it does not output a run time.

Printer: ?0043 FT 10:34:13.384

Display Board: no output

RS 232: ?0043 C1 10:34:13.384 (CR)



- As long as you press <ALT> and <BLOCK> of the finish-keyboard (15) together, the TdC 8000 will ignore all finish impulses (channel 1). The TdC 8000 does not store or output this time.

A stop impulse never stops the time on the display and display board as long as you press <BLOCK>.

4.2.3. Individual adjustment of the channels:

You can adjust each channel individual. When you turn the TdC 8000 on and clear the memory you have always all channels active.

- If you press <MENU> and <BLOCK> together it shows the setting of each channel in the info-display (6).
- Select the channel with and .
- Press <F1> to switch between activated and deactivated
- A (+) means, that the channel is activated.
- A (-) means, that the channel is deactivated.
- Leave the menu by pressing <MENU> and <BLOCK> together.

Info-display (6):

Channels on (+)/off (-): CHANGE F1

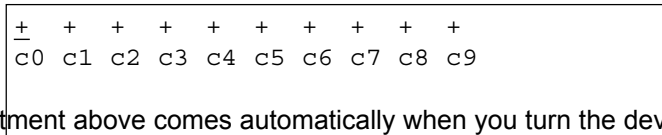

The adjustment above comes automatically when you turn the device after you cleared the memory:

The example bellow shows that channel c3 and c4 is switched off:

Channels on (+)/off (-): CHANGE F1

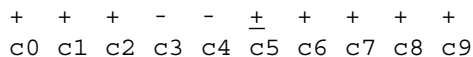



4.3. Editing of Times:

4.3.1. Editing of Start Times:

4.3.1.1. Clear Start Times:



- <CLEAR> of the start keyboard (9) clears the start time of the start number shown in the display (2).
- The cleared time is now marked with a c (c= cleared).
- The printer prints the time with the c prefix.
- The output of RS 232 interface looks like: c0043 C0 10:34:13.384

4.3.1.2. Restoring a Cleared Start Time:

- The correct start number must be shown in the start display (2). Then, press <ALT> and <CLEAR> on the start keyboard (9) together, it makes a valid time out of the cleared time.
 - It stores the time as valid start time.
 - The printer prints a valid start time.
 - The RS 232 interface sends the valid start time.
 - You can only restore the last start that was cleared.
- Especially useful if a time is accidentally cleared.

4.3.1.3. Changing Start Times:

This function is used at any time to edit start times. If you press the <INPUT> of the start keyboard (9) it is possible to edit the start time. The following editing is possible:

- over write a start time with keyboard (9)
- copy the start time of a start number to another start number (if a racer loses their original number).
- identify the correct start time from many recorded impulses.

Input functions:

- Press <INPUT> of the start keyboard (9)
- The info-display (6) shows the valid start time of the start number you wish to edit.

Input: 0015 C0 13:15:35.486 NEW No F1 e.g. start number 15,
the last digit of the start number
blinks, you can confirm or
over write the start number

- You can increment through the start list with the cursor keys (↑ and ↓) or over write the start number with the start keyboard (9).
- Confirm your choice with <ENTER>
- The cursor is now at the first digit of the time:

```
Input: 0015 C0 13:15:35.486      NEW No F1 valid time
        c0015 C0 13:10:12.498      time cleared with <CLEAR>
        ?0015 C0 13:17:28.938      time not valid (e.g. from
<BLOCK>)
```

- You can select the correct time with the cursor key (←) and (→). When you press <ENTER> it makes the selected time valid.
- You can also over write the valid time (first line) with the numbers of the start keyboard (9) (manual input of the start time).
- You can assign the selected time to another start number by pressing <F1> and input the new start number.
- Exit the input menu by pressing <INPUT> of the start keyboard (9) again.

Attention:

- If it shows 00:00:00.000 as start time it means, that you have no start time for this start number.
- If you make another start time valid, it replaces the old start time with a c (clear).
 e.g.: c 0009 ST 12:13.21.10

Group start: If you work with group start, you can change the start time like for the single start. In the input menu it shows instead of the start number the group number. You can change only the start time of the complete group, but not from a single competitor.

4.3.1.4. Input Start Times (Start Intervals):

Use this function to enter regular interval starts or group mass starts. The concept is that you will be a timing at the finish line, and that all starts will be manually input.

- Press <MENU> and <INPUT> together
- The info-display (6) shows the following:

```
Start interval from No: 0001 to No: 0002
      start time: 00:00:00.000
      interval: 00:00:00.000
Save with: ENTER
```

- Input the first and last start number of that category.
- Input the start time of the first start number
- Input the interval time (time between two starts). If you input 00:00:00.000 as interval time it means a mass start for the start numbers that you have input.

Attention:

- If you input the start times before the start and there is a start delay, it is necessary to input the start times again.
- If you input the same start numbers for different groups it takes always the last input as valid.

e.g.: Input start number 1 to 10, start time is 10 o'clock, interval time is one minute.

```
Start interval from No: 0001 to No: 0010
      start time: 10:00:00.000
      interval: 00:01:00.000
Continue with: ENTER
```

This input gives the following starting times:

start number 1	at 10:00
start number 2	at 10:01
start number 3	at 10:02
etc.	
start number 9	at 10:08
start number 10	at 10:09

Attention:

Use the <INPUT> key of the start keyboard (9) to input the start times, if you do not have regular intervals between the competitors (e.g. Nordic combination - Gunderson start).

4.3.2. Editing of Finish Times:



4.3.2.1. Clear Finish Times:

- <CLEAR> of the finish keyboard (15) clears the finish time of the start number shown in display (8).
- The run time gets replaced by the running time in the finish display (7).
- The cleared time is now marked with a c (c= cleared).
- The printer prints the time with a c prefix.
- The output of RS 232 interface looks like: c0043 C1 10:35:33.854

4.3.1.2. Restoring a Cleared Finish Time:



- The correct start number must be shown in the finish display (8). Then, press <ALT> and <CLEAR> on the finish keyboard (15) together, it makes a valid time out of the cleared time.
 - The finish display (7) resumes the running time.
 - It stores the time as valid finish time.
 - The printer prints a valid finish time.
 - The RS 232 interface sends the valid finish time.
 - You can only restore the last finish that was cleared.
- Especially useful if a time is accidentally cleared.

4.3.2.3. Changing Finish Times:

This function is used at any time to edit finish times. If you press the <INPUT> of the finish keyboard (15) it is possible to edit the finish time of the start number shown on the finish display (8). The following editing is possible:

- over write a finish time with keyboard (15)
- copy the finish time of a start number to another start number (if you fail to identify the racer correctly when he cross the line).
- identify the correct finish time from many recorded impulses.
- Disqualification of a competitor (start number)

Input functions:

- Press <INPUT> of the finish keyboard (15)
- The info-display (6) shows the valid finish time of the start number you wish to edit.

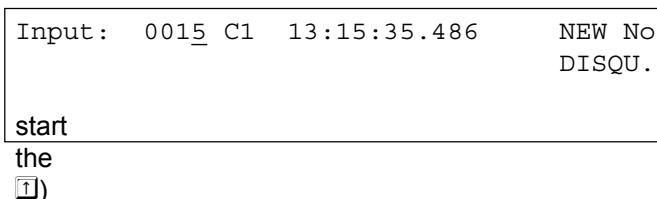

NEW No F1 e.g. start number 15,
DISQU. F2 the last digit of the start number blinks, you can over write the number or change it with cursor keys (←) and (→)

- You can increment through the finish list with the cursor keys (←) and (→) or input the start

number with the finish keyboard (15).

- Confirm the start number with <ENTER>
- The cursor is now on the first digit of the time:

```
Input:  0015 C1 13:15:35.486      NEW No F1      valid finish time
        c0015 C1 13:10:12.498      DISQU. F2      time cleared with <CLEAR>
        ?0015 C1 13:17:28.938                                     time not valid (e.g. from <BLOCK>)
```

- You can select the correct finish time with the cursor key (↓ and ↑). When you press <ENTER> it makes the selected time valid.
- You can also over write the valid finish time (first line) with the numbers of the finish keyboard (15) (manual input of the finish time).
- If you want to give the selected time to another start number press <F1> and input the new start number.
- To disqualify the competitor (start number) press <F2>. The disqualified time is marked with a d. For a disqualification it clears the start time, finish time, and run time. 
- Exit the input menu by pressing <INPUT> of the finish keyboard (15) again.

Attention:

- If it shows 00:00:00.000 as finish time, it means that you have no finish time for this start number.
- If you make another finish time valid, it stores the old finish time with a c (clear).
E.g.: c 0009 FT 12:15.22.157

4.3.2.4. Editing Run times, Memory Times, and Intermediate Times:

If you press <MENU> and <INPUT> of the finish keyboard (15) together you get into the menu to edit run times, memory times, and intermediate times.

- Press <MENU> and <INPUT> at the same time.
- The info-display (6) shows the following:

```
Input times:                                RUN TIME< F1 <F1> to change the run time
                                                MEMORY TIME F2 <F2> to change the memory time
                                                INTERMEDIATE TIME F3 <F3> to change the intermediate
Continue: ENTER                               time
```

- Select the time you want to change with <F1>, <F2> or <F3> or ↓ and ↑.
- Changes are made like described in following three chapters.
- Exit the menu by pressing <MENU> and <INPUT> together.

4.3.2.4.1. Editing a Run time:

You can edit the following:

- over write a run time with keyboard (15)
- copy the run time of a start number to another start number.
- Disqualification of a competitor (start number)

Changing a run time:

- Press <MENU> and <INPUT> together
- Press <F1>

- Press <ENTER>
- The info-display (6) shows the valid run time of the start number shown in the finish display (8):

```
Input:  0015 RT  00:01:35.139      NEW No F1  e.g. start number 15
        DISQU. F2
```

- You can change the start number with the cursor keys (← and →) or input the start number with the finish keyboard (15).
- Confirm the start number with <ENTER>
- The cursor is now on the first digit of the time:

```
Input:  0015 C1  00:01:35.486      NEW No F1      valid finish time that you can
        DISQU. F2                      over write
```

- You can over write the valid run time with the numbers of the finish keyboard (15) (manual input of the run time).
- If you want to copy the selected time to another start number press <F1> and assign it.
- To disqualify the competitor press <F2>. The disqualified time is marked with a d. For a disqualification it clears the start time, finish time, and run time.
- Exit by pressing <MENU> and <INPUT> of the finish keyboard (15) together.



- Attention:**
- If it shows 00:00:00.000 as run time, it means that you have no run time for this start number.
 - If you make another run time valid, it stores the old run time with a c (clear).
e.g.: c 0009 RT 00:01:35.486

4.3.2.4.2. Editing a Memory Time:

You can edit the following:

- over write a memory time with keyboard (15)
- you can copy the memory time to another start number.
- disqualification of a competitor (start number)

Changing a memory time:

- Press <MENU> and <INPUT> together
- Press <F2>
- Press <ENTER>
- The info-display (6) shows the valid memory time of the start number shown in the finish display (8):

```
Input:  0015 MT  00:01:35.139      NEW No F1  e.g. start number 15
        DISQU. F2
```

- You can change the start number with the cursor keys (← and →) or input the start number with the finish keyboard (15).
- Confirm the start number with <ENTER>
- The cursor is now on the first digit of the time:

```
Input:  0015 C1  00:01:32.446      NEW No F1      valid finish time that you can
```

DISQU. F2 over write

- You can over write the valid memory time with the finish keyboard (15) (manual input of the finish time).
- If you want to copy the selected time to another start number press <F1> and assign it.
- To disqualify the competitor press <F2>. The disqualified time is marked with the prefix d. For a disqualification it clears the start time, finish time, and run time.
- Exit the menu by pressing <MENU> and <INPUT> of the finish keyboard (15) together.

Attention:

- If it shows 00:00:00.000 as memory time, it means that you have no memory time for this start number.
- If you make another memory time valid, it stores the old memory time with a c (clear).
E.g.: c 0009 MT 00:01:32.446

4.3.2.4.3. Changing a Intermediate Time:

You can edit the following:

- over write a memory time with keyboard (15)
- you can copy the memory time to another start number.

Changing a intermediate time:

- Press <MENU> and <INPUT> (finish keyboard 15) together
- Press <F2> (1st heat) or <F3> (2nd heat)
- Press <ENTER>
- Input the channel number that you want to edit:

Input channel number: #

e.g. channel 2

Save with: ENTER

- Input the channel number with the finish keyboard (15). Input from 2 to 9 is possible.
- Confirm with <ENTER>.
- The info-display (6) shows the intermediate time of the start number shown in the display (8):

Input: 0015 C2 00:00:34.557 NEW No F1 e.g. start number 15
 CLEAR F2 to clear the intermediate time

- You can change the start number with the cursor keys (←) and (→) or input the start number with the finish keyboard (15).
- Confirm the start number with <ENTER> (finish keyboard 15).
- The cursor is now on the first digit of the time:

Input: 0015 C1 00:00:34.557 NEW No F1 valid intermediate time that you
 CLEAR F2 can over write

- You can over write the valid intermediate time with the finish keyboard (15) (manual input).
- If you want to copy the selected time to another start number press <F1> and assign it.

- Exit the menu by pressing <MENU> and <INPUT> of the finish keyboard  together.

Attention:

- If it shows 00:00:00.000 as memory time, it means that you have no memory time for this start number.
- If you make another intermediate time valid, it stores the old intermediate time with a c (clear).

E.g.: c0009 C2 00:01:32.446

4.4. MEMO - Time Buffer for Mass-Finish-Arrivals:

This function allows you to record and identify groups of racers that come to the line at the same time. You can enter and exit the MEMO-function at any time without danger of losing any time.

If two or more competitors reach the finish at the same time, it is usually not possible to input the start number as fast as the finish impulses arrive. In this case we use <MEMO>. After the arrival of the racer group you can input their start numbers, which will then create a valid run time for each.

- Group of competitors arrives at the finish.
- Press <MEMO>
- Write the start numbers of the group in order on paper or use a tape recorder.
- All times are stored in chronological order with a continuous ID-number.
- The printer prints every time marked with the prefix m.

RS 232 output: m####xCCCxHH:MM:SS.zhtqxGR (CR)
Printer output: m####xCCCxHH:MM:SS.zht
 m identification a memory time
 #### every memo time gets continuous ID-number
 CCC timing channel (e.g. C1 for finish time, C1M for manual finish time)
 HH:MM:SS.zhtq ... time with 1/10.000 seconds
 HH:MM:SS.zht time with 1/1000 seconds
 GR group
 x blank
 (CR) carriage return

Assign the correct start number to the times in memory:

As soon as the first competitor goes through the finish you can input the start number and confirm it with <ENTER> of the finish keyboard (8). The channel ID is shown for each time and identifies the score of the impulse. Remember that C1 is the finish channel.

- The info-display (6) shows the following:

Memory:	1	C1	13:05:11.3451	No:	—	first time in memory, channel 1
	2	C1	13:05:12.3892			second time in memory, channel 1
	3	C2	13:05:15.9848			third time in memory, channel 2
	4	4	C1	13:05:15.4566		fourth time in memory, channel 1

- The four in the lower left corner shows that you have four times stored in the memory.
- The cursor is in the upper right corner, ready to input the start number

- Input the start number (finish keyboard 15), e.g. start number 34
- Confirm the start number with <ENTER>
- The time and start number disappears and each line moves up.

```
Memory:      2  C1  13:05:12.3892 No:      _  second time in memory, channel 1
              3  C2  13:05:15.9848                third time in memory, channel 2
              4  C1  13:05:15.4566                fourth time in memory, channel 1
```

3

- Input the start number (finish keyboard 15), e.g. start number 12
- Confirm the start number with <ENTER>
- The time and start number disappears and each line moves up.
- With ↓ and ↑ it is possible to move the times up and down.
- Input all start number as before.
- Press <MEMO> to exit the MEMO-menu

Assigning the same time to two or more competitors:

You can assign the same time to two or more competitors, if you only receive one impulse from a sensor.

```
Memory:      1  C1  13:05:11.3453 No:      _  Only one time for two competitors
```

1

- Input the first start number with finish keyboard (15), e.g. start number 55
- Confirm the start number with <INPUT>
- It stores and prints the time and the start number
- The same time is still on the info-display (6)

```
Memory:      1  C1  13:05:11.3453 No:      _  The same time is in the display
```

1

- Input the start number with the finish keyboard (15), e.g. start number 10
- Confirm the start number with <INPUT> if you have more numbers to assign, or <ENTER> for the final entry.
- The time and start number disappears, the Memo-memory is empty.
- Press <MEMO> to exit the MEMO-menu

- Attention:**
- You can delete a false time in the memo-mode by pressing <CLEAR> on the finish keyboard (15).
 - You can enter and exit the MEMO-function at any time without danger of losing any time.

Each Memo-Time is shown with a continues ID-number. This number can help you to find the time again later.

If you clear a time in the MEMO mode with <CLEAR>, you can find it again when pressing <INPUT> and enter start number zero.

Memo-times cleared with <CLEAR> are marked with a capital C.
Run-times cleared with <CLEAR> are marked with a small c.



4.5. CLASS - Classement

4.5.1. Classement in Heat 1:

If you press <CLASS> it is possible to print a classement of the race.

You can print the Classement with race points (for skiing).

Each classement has an output on the printer, on the RS 232 interface and on the "display-board" interface (on channel 2).

A classement for the first heat prints the following:

1.			first rank
0003	RT	0:49.52	start number 3 and run time
2.			second rank
0011	RT	0:49.69	start number 11 and run time
3.			third rank
0008	RT	0:50.02	start number 8 and run time

The classement for the second heat prints the following:

1.			first rank
0011	RT	0:50.12	start number 11 and run time
	MT	0:49.69	memory time
	TT	1:39.81	total time
2.			second Rank
0003	RT	0:50.69	start number 3 and run time
	MT	0:49.52	memory time
	TT	1:40.21	total time
3.			3. Rang
0008	RT	0:50.72	start number 8 and run time
	MT	0:50.02	memory time
	TT	1:40.74	total time

If you press <CLASS> it shows on the info-display (6):

Classement :	ALL < F1
	GROUPS F2
	CLASSES F3
Continue: ENTER	SINGLE F4

- If you press six times **[↓]** the info-display (6) shows the following:

```

Classement :                               SINGLE F1
                                               LEADING TEN F2
                                               NOT FINISHED F3
Continue: ENTER                               ADD< F4
  
```

- If you press three times **[↓]** the info-display (6) shows the following:

```

Classement :                               ADD< F1
                                               DISQUALIFIED F2
                                               START ORDER F3
Continue: ENTER                               PROTOCOL F4
  
```

- You can choose between ten different classifications
- Select with **[↓]** and **[→]** or <F1>, <F2>, <F3>, <F4>
- If you have selected the classement press <ENTER>
- You can select, if you want to make a classement of the run times, or intermediate times.

```

Classement :                               RUN TIME< F1
                                               INTERMEDIATE TIME F2
  
```

Continue: ENTER

- If you press <F1> it prints a result list of the run times.
- If you press <F2> it prints a result list of the intermediate times.
- You can choose, if you want to calculate race points (for Alpine-Ski or Nordic-Ski):

```

Classement :                               NO RACE POINTS< F1
                                               RACE POINT BEST TIME F2
                                               RACE POINT START NUMBER F3
  
```

Continue: ENTER

- If you press <F1> and <ENTER> it calculates no race points
- If you press <F2> and <ENTER> it calculates race points related to the best time
- If you press <F3> and <ENTER> it calculates race points related to the start number that you input.

- **All:** It prints the actual result list of all finished competitors, this means each who has a valid run time.

- **Groups:** For a group classement need to work with groups. Groups you have to input before the race starts or later in the main menu (see page 57). If you select groups, than you have to select if you want to print all groups (<F1>) or a single group (<F2>).

```

Classement :                               ALL< F1
                                               SINGLE F2
  
```

Continue: ENTER

ALL: Classement of each group

SINGLE: Classement of a selected group. Input the group number and confirm it with <ENTER>. When you have selected the last group press twice <ENTER>.

```

Classement :                               Gr :  0
                                          
Select : ENTER
  
```

- **Classes:** If you use "Classes" to make the ranking, it offers you a wide variety to make different ranking lists. You can create your own classes, independent from the groups that you have input. You can make e.g. a classement including some groups, or you can make a classement within a group. It is also possible to add late entries to a group, that have start numbers which are not within the group range.

You must make all input for Classes with the finish keyboard (15).

```

Classement :                               No :  0>  0
  
```

Save with: ENTER

Input always the first and last start number of a class and confirm with <ENTER>. It is also possible to add different start number section together to a classes classement:

```

Classement :                               No :  4>  10
                                           No :  21>  25
                                           No :  51>  55
Save with: ENTER
  
```

If you want to execute the classement of the numbers that you input, press two times <ENTER>.

The classement of the above example would include the following start numbers: 4, 5, 6, 7, 8, 9, 10, 21, 22, 23, 24, 25, 51, 52, 53, 54, 55

- **Single:** A classement of individual single start numbers is possible. This is e.g. necessary to make a classement within a team.

```

Classement :                               No :  _
  
```

Continue: ENTER

- Input all start numbers that you want in the classement.
E.g. 12 <ENTER>, 24 <ENTER>, 134 <ENTER>, 53 <ENTER>
- The info-display (6) shows the following:

Classement : No: 12
 No: 24
 No: 134
 No: 53

Continue: ENTER

- Press <ENTER> again after you have input all start numbers.
- Select if you want to calculate race points.
- It prints the classement (e.g. form start number 12, 24, 53, and 134).
- Output of the same classement through the RS 232 interface.

- **First Ten:** It prints a classement with the fastest competitors within the race.

CLASSEMENT:
 RUN TIME
 LEADING TEN

1.
 0009 RT 1:30.45
 2.
 0014 RT 1:30.56
 3.
 0008 RT 1:30.71
 etc..
 9.
 0002 RT 1:31.69
 10.
 0020 RT 1:31.99

- **Not Finished:** It prints all start numbers that have a start time, but no finish time (run time).

CLASSEMENT:
 RUN TIME
 NOT FINISHED

0004
 0028
 0052
 0109

- **Add:** A addition of times of different start numbers is possible. The add time is necessary e.g. to make a team classement.

Classement : No: _

Continue: ENTER

- Input start numbers that you want to add.
 E.g.: 9 <ENTER>, 14 <ENTER>, 72<ENTER>, 102<ENTER>
- The info-display (6) shows:

```

Classement :
.
Continue: ENTER
No: 9
No: 14
No: 72
No: 102
  
```

- After you have input all start numbers, press <ENTER> again.
- It prints the times of start number 9, 14, 72, and 102.
- It prints the added time of these competitors.

```

CLASSEMENT :

      RUN TIME
      ADD

0009 RT      1:31.45
0014 RT      1:30.09
0072 RT      1:33.41
0102 RT      1:35.69
      ADD      6:10.64
  
```

- **DISQUALIFIED:** It prints all start numbers that were disqualified (with <INPUT> of finish keyboard)

```

Classement :

      DISQUALIFIED

0007
0024
0107
  
```

- **Start Order:** If you make the second (or higher) head, it is possible to print the start order for the heat. This function is very nice if you start after the bibo rule in the second run.

- **Protocol:** A protocol is always printed in the memory order. You can print a protocol of the following times:

- start time
- finish time
- intermediate time
- run time

Select with the cursor (< or >) or the F-key the times that you want to print:

```

Classement :
START TIME< F1
FINISH TIME F2
INTERMEDIATE TIME F3
Continue: ENTER RUN TIME F4
  
```

You can select to print all data from the selected time with <F1>, or only the selected data from the selected time with <F2>.

Continue: ENTER

Example of a classement with race point calculation:

1.			first rank
0003	RT	1:49.52	start number 3 and run time
RP	00000.00		race points for start number 3
2.			second rank
0011.	RT	1:49.69	start number 11 and run time
RP	00012.34		race points for start number 11
3.			third rank
0017.	RT	1:50.69	start number 17 and run time
RP	00032.34		race points for start number 17

4.6. PRINT - Switching the Printer off or on:



When you switch TdC 8000 on it activates the printer automatically. After you selected the program you can make the following adjustments for the printer:

Print-Mode:

The printer prints all data. The printer is automatically in this mode, when you switch the TdC 8000 on.



Buffer-Mode:

All data for the printer are stored in the buffer. This mode you use e.g. to change the paper.

- Printer is in Print-Mode
- Press <PRINT>
- Printer is now in the Buffer-Mode
- Press <PRINT>
- Printer is again in the printing mode. It prints now all data collected during the buffer mode.

Printer Off:

The printer is off and all data for the printer are lost.

- Printer is in Print-Mode
- Press <ALT> and <PRINT> at the same time
- Printer is switched off
- Press <ALT> and <PRINT> at the same time
- Printer is in Print-Mode

5. MAIN MENU - GENERAL ADJUSTMENTS

The TdC 8000 is a very universal timing device. To offer a wide range of timing solutions it is possible to adjust each program individually.

If you make changes in the main menu it stores these new values after you turn the machine off.

If you want to have the ALGE standard configuration do the following:

- turn TdC 8000 off (switch 26)
- press <ALT> and <MENU> together and keep it pressed
- turn TdC 8000 on (switch 26)
- release <ALT> and <MENU> after five seconds
- the main menu has now the ALGE standard configuration

You can also check and change the main menu set up through the RS 232 interface (see page 97, chapter 8.2.1 and page 98, chapter 8.2.2).

How do you get into the main menu:

- Select program
- press <ALT> and <MENU> together
- Press **[↓]** and **[↑]** to go through the menu. With the numeric keys of the finish keyboard (15) you can select a menu direct.
- Select the chosen menu with <YES>

Mean Menu - Short Description:

Menu 1: Delay Time Start = 1.00 s	Adjustable: from 0.01 to 9.99 seconds
Menu 2: Delay Time Finish = 0.30 s	Adjustable: from 0.01 to 9.99 seconds
Menu 3: Seconds Mode = OFF	Adjustable: ON or OFF
Menu 4: Display Time 1 = 03 s	Adjustable: from 0 to 99 seconds
Menu 5: Display Time 2 = 03 s	Adjustable: from 0 to 99 seconds
Menu 6: Display Thousandth = OFF	Adjustable: ON or OFF
Menu 7: Info-Display = START	Adjustable: START, FINISH, or OFF
Menu 8: Running Time = RUN	Adjustable: RUN or TOTAL
Menu 9: Running Tenth = OFF	Adjustable: ON or OFF
Menu 10: Intermediate Rank = ON	Adjustable: ON or OFF
Menu 11: Finish Rank = ON	Adjustable: ON or OFF
Menu 12: STNO Automatic = OFF	Adjustable: START, FINISH, or OFF
Menu 13: Print Start Time = OFF	Adjustable: ON or OFF
Menu 14: Print Menus = ON	Adjustable: ON or OFF
Menu 15: Print Linefeed = 0	Adjustable: from 0 to 9
Menu 16: RS-232 Baudrate = 9600 Bd	Adjustable: 2400, 4800, or 9600 Baud
Menu 17: RS-232 Run time = OFF	Adjustable: ON or OFF
Menu 18: D-Board Baudrate = 2400 Bd	Adjustable: only 2400 Baud
Menu 19: D-Board Channel 2 = RUNNING	Adjustable: RUNNING or STANDING
Menu 20: Beep = ON	Adjustable: ON or OFF
Menu 21: Handicap time = 00:00:00.00	Input handicap time (no function yet)
Menu 22: Groups = OFF	Depending of the amount of groups
Menu 23: Change Run	Adjustable: SAME or NEXT run
Menu 24: Change Race	You can select another race
Menu 25: D-Board-Test	Test program for the display board
Menu 26: ID channel 4 = b (blue)	Adjustable: b (blue) or L (left)
Menu 27: Penalty Time = 1.500 s	Adjustable: from 0.000 to 9.999
Menu 28: Start Channel = separate	Adjustable: SEPARATE or COMMON
Menu 29: Rank Calculation = separate	Adjustable: SEPARATE or COMMON
Menu 30: Print Times = OFF	Adjustable: ON or OFF
Menu 31: Distance = 0100 m	Adjustable: 1 to 9999 m
Menu 32: Measuring Unit = km/h	Adjustable: km/h, m/s, or mph
Menu 33: Min. Speed = 0010 km/h	Adjustable: 1 to 9999 (km/h, m/s, or mph)
Menu 34: Max. Speed = 0200 km/h	Adjustable: 1 to 9999 (km/h, m/s, or mph)

Pre adjusted value: Display Time 1 = 3 seconds

Display Time 2:

Menu 5: DISPLAY TIME 2 = 03 s

You can adjust the amount of time that it shows the second stopped time in the second heat (total time or run time) on the display (7) or display board. This time we call display time 2. You can select the display time between 0 and 99 seconds.

Menu 5: DISPLAY Time 2 = 03 s
 (15)

input seconds with finish keyboard

Save with: ENTER

Confirm input with <ENTER>

Pre adjusted value: Display Time 2 = 3 seconds

Display Thousandth:

Menu 6: DISPLAY THOUSANDTH = OFF

Normally the display (7) does not show the 1/1000 seconds. If you want to show the 1/1000 on the display, it must shift the time two digit to the left. In this mode you can not show the hours on the display. This adjustment you can only select if you work with 1/1000 precision.

Menu 6: DISPLAY THOUSANDTH
 seconds

OFF F1 display shows 1/1000

ON< F2 display shows 1/100 seconds

Save with: ENTER

confirm selection with <ENTER>

on = <F1> display (7) shows 1/1000 seconds, but no hours

off = <F2> display (7) shows 1/100 seconds, but no 1/1000 seconds

Pre adjusted value: Display thousandth is off

Info-Display:

Menu 7: INFO-DISPLAY = START

You can adjust the display mode during the timing for info-display (6).

Menu 7: INFO-DISPLAY

START< F1 Start display

FINISH F2 Finish display

OFF F3 no timing information

Save with: ENTER

Confirm selection with <ENTER>

Start: The info-display shows always the running time. You can only select this mode for single start in the program SPLIT. The F-keys have the following functions:

<F1> shows first started time

<F2> shows actual time, that means the last finish time in the first line of the display

<F3> shows last started time

Finish: In the info-display it shows always the finish times (intermediate times). The F-keys have the following functions:

<F1> shows the first intermediate time of finish time in the race in the top line

<F2> shows the last stopped time in the top line of the info-dispaly (6)

<F3> shows the last stopped time in the bottom line of the info-dispaly (6)

OFF: The info-display (6) does not show times.

Running Time: Menu 8: RUNNING TIME = RUN

You can select if you want to show for the second heat (third, etc.) in the display (7) and on the display board the running run time or the running total time.

E.g.: the run time for the first run of start number 5 is 1:30.45

For heat: Time starts in the second heat form 0:00.00
 For total: Time starts in the second heat from 1:30.45

Menu 8: RUNNING TIME RUN< F1 shows the run time
 TOTAL F2 shows the total time

Save with: ENTER Confirm with <ENTER>

Pre adjusted value: Run time

Running Tenth: Menu 9: Running Tenth = ON

The finish display (7) and the interface "display board" (24) can output the running tenth second (the ALGE-display-board cannot show the running tenth second). The running tenth second is important to feed a video generator (for TV).

on = <F1>running tenth second is on
 off = <F2>running tenth second is off

Menu 9: RUNNING TENTH ON F1 running tenth second is on
 OFF< F2 running tenth seconds is off

Save with: ENTER confirm with <ENTER>

Pre adjusted value: running tenth seconds are on

Rank for Intermediate Time: Menu 10: INTERMEDIATE RANK = ON

You can show the rank for the intermediate time on the display (7) and display board. It shows the rank as long as you have the display time adjusted (see menu 4). If you use more than one intermediate times, then you must use for each intermediate time a separate channel (c2 to c9).

Menu 10: INTERMEDIATE RANK ON< F1 shows rank
 OFF F2 no rank is shown

Save with: ENTER confirm with <ENTER>

Pre adjusted value: intermediate time rank is on

Rank for Finish Time: Menu 11: FINISH RANK = ON

For each run time (or total time) it shows the rank on display (7) and on the display board. It shows the rank as long as you have the display time adjusted (see menu 4).

Menu 11: FINISH RANK ON< F1 shows rank
 OFF F2 no rank shown

Save with: ENTER confirm with <ENTER>

Pre adjusted value: rank for finish time is on

Start Number Automatic: **Menu 12: STNO AUTOMATIC = OFF**

The start number input for the TdC 8000 you can automate for start and finish.

START: Only one competitor is allowed on the slope. If the competitor is in the finish the next can start. As long as the competitors start in order (1, 2, 3, 4, etc.) and no competitor does not finish you do not have to input a start number manual for start or finish.

FINISH: As many competitors can be on the slope as you want. The start number shown in display (2) goes after each start up to the next number. The start number shown in the display (7) goes after each finish up to the next number.

Start = <F1> start automatic is on
 Finish = <F2> finish automatic is on
 off = <F3> manual input of start numbers is necessary

```

Menu 12: STNO AUTOMATIC          START< F1 Automatic "START"
                                FINISH F2 Automatic "FINISH"
                                OFF    F3 Manual input of start numbers
Save with: ENTER                  Confirm selection with <ENTER>
  
```

Pre adjusted value: start number automatic is off

Print Start time: **Menu 13: PRINT START TIME = OFF**

You can print the start time with the start impulse. Normally it prints the start time only when you receive the finish impulse.

on = <F1> prints start time with the start
 off = <F2> prints no start time during the start

```

Menu 13: PRINT START TIME          ON< F1 print start time immediately
                                OFF  F2 print start time with finish
Save with: ENTER                  confirm selection with <ENTER>
  
```

Pre adjusted value: it prints no start time during the start (OFF)

Print Menus: **Menu 14: PRINT MENUS = ON**

Whenever you change an ALGE adjustment in the menus it prints the new adjustment (e.g. during the switch on procedure). If you select "PRINT MENUS = OFF" it will not print the menu adjustments. Also changes made in the main menu wont be printed.

on = <F1> it prints the menu adjustments
 off = <F2> it does not print the menus adjustments

```

Menu 14: PRINT MENUS              ON< F1 print menu adjustments
                                OFF  F2 do not print menu adjustments
Save with: ENTER                  confirm selection with <ENTER>
  
```

Pre adjusted value: print menu adjustments

Printer Linefeed: Menu 15: PRINTER LINEFEED = 0

The printer can print after each paragraph linefeed (e.g. two linefeed to have the printed lines above the cutter). You can adjust between 1 and 9 linefeeds. If you use zero (ALGE adjustment) it prints in every line.

Menu 15: PRINTER LINEFEED = 0 input amount of linefeed

Save with: ENTER confirm selection with <ENTER>

Pre adjusted value: Printer prints in every line (printer linefeed = 0)

RS 232 Baudrate: Menu 16: RS-232 BAUDRATE = 9600 Bd

You can adjust the baud rate of the RS 232 interface (23) between 2400, 4800, or 9600 baud.

Menu 16: RS-232 BAUDRATE 2400 Bd F1 Select with <F1>
 4800 Bd F2 Select with <F2>
 9600 Bd F3 Select with <F3>
 Save with: ENTER Confirm selection with <ENTER>

Pre adjusted value: 9600 Baud

RS 232 Run Time: Menu 17: RS-232 RUN TIME = OFF

The RS 232 interface (23) outputs always in the difference-timing mode the time of day. Additional you can output the run time.

output time of day and run time = <F1>
 output time of day = <F2>

Menu 17: RS-232 RUN TIME ON F1 output run time and time of day
 OFF< F2 output time of day

Save with: ENTER Confirm selection with <ENTER>

Pre adjusted value: RS-232 output is time of day

Display Board Baudrate: Menu 18: D-Board Baudrate = 2400 Bd

The display board works only on a baud rate of 2400. Other baud rates are not possible.

Pre adjusted value: D-Board Baudrate = 2400 Baud

Display Board Channel 2: Menu 19: D-BOARD CHANNEL 2 = OFF

You can adjust the channel 2 of the display board interface (24). If you have channel two on STANDING, it outputs no running time (only run times). It outputs the classement always on channel 2. You can select between channel 1 and channel 2 by turning the plug of the display board cable 180°.

Menu 19: D-BOARD CHANNEL 2	RUNNING	F1 output of running time
	STANDING<	F2 output of run times
Save with: ENTER		Confirm selection with <ENTER>

RUNNING = <F1> running time and classement
 STANDING = <F2> run time and classement

Pre adjusted value: D-Board Channel 2 is off (running time)

Beep: Menu 20: BEEP = ON

The beep makes a sound for each timing impulse. The length of the beep depends on the adjusted delay time. If the beep bothers people in the timing shack it is possible to turn it off. The beep goes automatically on, as soon as you turn the TdC 8000 on.

Menu 20: BEEP	ON	F1 Beep is on
	OFF<	F2 Beep is off
Save with: ENTER		Confirm selection with <ENTER>

Pre adjusted value: Beep is on

Handicap Time: Menu 21: HANDICAP TIME = 00:00:00.00

Information that tell the percentage advantage or disadvantage compared to the handicap time. The handicap time is activated as soon as you input a time.

Menu 21: HANDICAP TIME = 00:00:00.00 (15)	Input handicap time with keyboard
Save with: ENTER	Confirm with <ENTER>

Output on the printer: 0012 SZ 10:58:11.320
 ZZ 10:58:41.693
 RT 0:30.37
 HANDICAP: +001.60%

Pre adjusted value: no handicap calculation, Handicap = 00:00:00.000

Input of Groups: Menu 22: GROUPS = OFF

If you want to show the rank within groups or make a group classement it is necessary to input the groups. You can input the groups when you start the TdC 8000 or in the main menu. In the main menu you can also correct groups.

123456789 <F1> each digit shows its position number
 0 <F2> each single digit counts form 0 to 9
 8 <F3> each single digit switch between blank and 8
 888888888 <F4> all digits switch between blank and 8

Pre adjusted value: GAZ-Test is not active

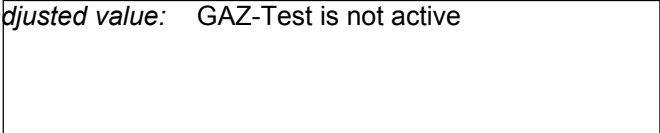

ID for Channel 4 in Parallel Slalom:

Menu 26: ID CHANNEL 4 = b (blue)

You can select the ID for winner on channel 4 in parallel slalom (for printer, display board, and RS 232). Depending on what you want to output for the winner course, red and blue, or right and left you can select the output of channel 4 with "b" or "L".

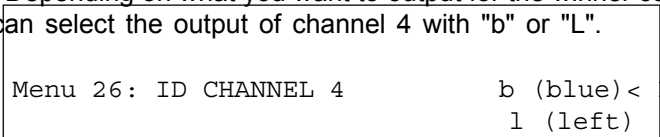

Save with: ENTER

Pre adjusted value: ID channel 4 = b (blue)

Penalty Time for Parallel Slalom:

Menu 27: Penalty Time = 1.500 s

If a competitor does not finish the first run, he gets a penalty time for the second run. This penalty time you can input in this menu.

If you want to work without penalty time input 0.000 as penalty time.

The finish difference time starts to run, when the first competitor reaches the finish. If the second competitor does not reach the finish before the time reaches the penalty time, it will show the penalty time on the display (7) and on the display board.

Menu 27: PENALTY TIME = 1.500 s

Save with: ENTER

Pre adjusted value: Penalty Time = 1.500 seconds

Start Channel for Dual Timer:

Menu 28: START CHANNEL = SEPARATE

You can select for the Dual Timer, if you want the start channel for both courses separate, or for both together. If you select both start courses common, it will start with an impulse of channel 0 or 3 both times.

6. PROGRAMS

The TdC 8000 has a very flexible software that suits for most timing problems.

You can select the following programs:

Programm	Program Number	Page
Split	Program 1	63
Sequential	Program 2	in preparation
Split Sequ.	Program 3	66
Parallel Diff.	Program 4	70
Parallel Net	Program 5	74
Dual Timer	Program 6	80
Speed	Program 7	84
Speed Skiing	Program 8	88
TdC Test	Program 9	90

To can select between the programs when you turn the TdC 8000 on. After about 5 seconds it shows the program that you used last time. Press <ENTER>, if you want to select this program.

Use the cursor keys (**↑** and **↓**) to select another program. When it shows the correct program in the info-display (6) press <ENTER>.

You can also input the program number direct with the finish keyboard (15). Confirm the number with <ENTER>.

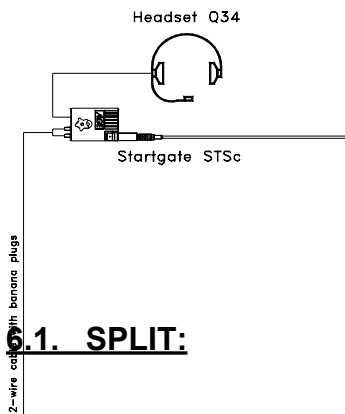

0.1. SPLIT:

Program 1

Net timing with up to 256 heats and up to 9999 competitors on the slope (e.g. Alpine Skiing, Nordic Skiing, Time Trial for Cycling). You have a start channel (c0), a finish channel (c1) and up to eight intermediate channels (c2 to c10).

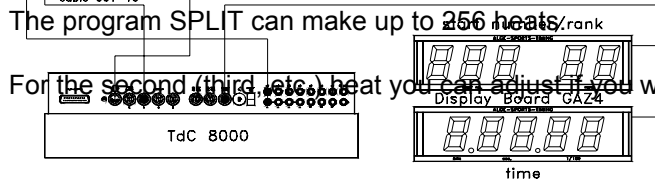

The program SPLIT can make up to 256 heats. For the second (third, etc.) heat you can adjust if you want to display the run time or total time.

e.g.: Alpine Ski or Cross Country Skiing:
Connect the TdC 8000 with a two wire cable with Startgate (c0).

The starter can communicate with the operator of TdC 8000 by using the headset Q34.

Connect the photocell RLS1c with the TdC 8000 (19 or 20) by using cable 0001-10.

The display board shows the run times and the start number and rank.

You can use additional photocells for the intermediate times.

Adjustment:

- Switch TdC 8000 on (switch 26)
- Select program SPLIT with cursor key (⌋ and ⌋)
- Press <ENTER>
- Select race that you want to use and clear memory (e.g. <F1> for race 1)
- Press <ENTER>
- Select race (e.g. <F1> for race 1)
- Press <ENTER>
- Select precision (e.g. <F3> for 1/100 precision)
- Press <ENTER>
- Select the timing mode (e.g. <F2> for difference timing)
- Press <ENTER>
- Select start mode (e.g. <F1> for single start)
- Press <ENTER>
- Press <YES> if you want to input groups for the race, otherwise <NO> or <ENTER>
 - if you input the groups input always the last start number within a group
 - confirm each start number with <ENTER>
 - after the start number of the last group you must press <ENTER> twice
- Synchronize the TdC 8000 (with time of day and other timing devices)
 - press <F1> if the finish display (7) shows the correct time of day
 - wait until TdC 8000 gives at the next full minute the synchronize signal to external devices (you are now ready for timing)
 - press <F2> if the finish display (7) shows the wrong time of day
 - input the time of day, confirm it with <ENTER> and make a start signal (channel 0 or press <START>

Race operation:

- Switch (1) in upper position
 - Input the start number for the start with start keyboard (9) (#1)
 - Press <ENTER>
 - The start-display (2) must show the correct start number (and group)
 - Input the start number for the finish with finish keyboard (15) (#1)
 - Press <ENTER>
 - The finish-display (8) must show the correct start number (and group)
 - Start number 1 starts
 - Display (7) shows the running time of start number 1
 - The start display (2) changes automatically to the next free start number 2
 - Start number 2 starts
 - The finish display (7) shows the run time of #2
 - The start display (2) changes automatically to the next free start number 3
 - Start number 1 goes through the finish
 - The finish display (7) shows the run time of start number 1
 - Start number 3 start
 - The start display (2) changes automatically to the next free start number 4
 - Press <ENTER> of the finish keyboard (15)
 - Display (7) shows the running time and display (8) the start number 2
 - Start number 2 goes through the finish
- | | |
|-------------------------|--------------------------------|
| Timing Channels: | c0 = start channel |
| | c5 = intermediate time channel |
| | c1 = finish channel |
| | c6 = intermediate time channel |
| | c2 = intermediate time channel |
| | c7 = intermediate time channel |
| | c3 = intermediate time channel |

channel c8 = intermediate time channel
 c4 = intermediate time channel c9 = intermediate time channel

ALGE adjustment for the main menu:

- Menu 1: Delay Time Start = 1.00 s
- Menu 2: Delay Time Finish = 0.30 s
- Menu 3: Seconds Mode = OFF
- Menu 4: Display Time1 = 03 s
- Menu 5: Display Time 2 = 03 s
- Menu 6: Display Thousandth = OFF
- Menu 7: Info-Display = START
- Menu 8: Running Time = RUN
- Menu 9: Running Tenth = OFF
- Menu 10: Intermediate Rank = ON
- Menu 11: Finish Rank = ON
- Menu 12: STNO Automatic = OFF
- Menu 13: Print Start Time = OFF
- Menu 14: Print Menus = ON
- Menu 15: Print Linefeeds = 0
- Menu 16: RS-232 Baudrate = 9600 Bd
- Menu 17: RS-232 Run time = OFF
- Menu 18: RS-232 Baud rate = 2400
- Menu 19: D-Board Channel 2 = RUNNING
- Menu 20: Beep = ON
- Menu 21: Handicap time = 00:00:00.00
- Menu 22: Groups = OFF
- Menu 23: Change Run
- Menu 24: Change Race
- Menu 25: D-Board-Test

Printer: Printing example

Heat 1:

0001	ST	10:05:58.990	start time
	FT	10:07:20.234	finish time
	RT	1:21.24	run time

Heat 2:

0001	ST	10:07:01.485	start time
	FT	10:08:22.385	finish time
	RT	1:20.90	run time
	MT	1:21.24	memory time
	TT	2:42.14	total time

Display Board GAZ4:

You can show the net time (running time) on one and the start number and rank on another display board. The display board shows always the actual start number that is shown in the finish display (8) (on the display board you can show the start number only with three digit and the rank with two digit).

In the main menu (menu 19, see page 56) it is possible to activate display board channel 2 . If you activate channel 2 it shows only the run times on the display board.

RS 232 interface: see on page 96, chapter 8.2

6.2. Sequential:

Program 2

Program in preparation!

6.3. Split-Sequential:

Program 3

Net timing and lap timing for events with single starts, or mass start. You can have as many competitors on the course as you want. This program is used e.g. for relay in Nordic Skiing. You can use a start channel, an intermediate channel, and up to 8 intermediate channels.

If you select the Split-Sequential program you must input the amount of laps prior to the race. The time stops for each a competitor on the display and display board for the adjusted display time 1 and starts then to run again.

You can make up to 256 heats with this program. If you start a new heat, it takes the total times of the previous heats.

You can adjust, if you want to start the time in the second heat (or a higher heat) from zero, or as total time.

The Split-Sequential program has no Group-Function!

Adjustment:

- Switch TdC 8000 on (switch 26)
- Select program 3 SPLIT-SEQU. with cursor key (↓) and (→)
- Press <ENTER>
- Select race that you want to use and clear memory (e.g. <F1> for race 1)
- Press <ENTER>

- Select race (e.g. <F1> for race 1)
- Press <ENTER>
- Input the amount of laps, e.g. 3, and confirm it with <ENTER>.
- Select precision (e.g. <F3> for 1/10 precision)
- Press <ENTER>
- Select the timing mode (e.g. <F2> for difference timing)
- Press <ENTER>
- Select start mode (e.g. <F2> for mass start)
- Press <ENTER>
- Synchronize the TdC 8000 (with time of day and other timing devices)
 - press <F1> if the finish display (7) shows the correct time of day
 - wait until TdC 8000 gives at the next full minute the synchronize signal to external devices (you are now ready for timing)
 - press <F2> if the finish display (7) shows the wrong time of day
 - input the time of day, confirm it with <ENTER> and make a start signal (channel 0 or press <START>

Race operation e.g. with mass start and three laps:

- Switch (1) in upper position
- For mass start you do not have to input the start number for the start.
- The start display (2) shows "1" in the group field.
- Input the start number for the finish with finish keyboard (15) (e.g. #1)
- Press <ENTER>
- The display (8) must show the correct start number and the display (7) must show the time zero.
- You get a start impulse that starts all competitors (mass start).
- Display (2) shows now 1u (u = used, which means that the start is done).
- Display (7) shows the running time, and display (8) shows start number 1 and at the group position 1 for first lap.
- Start number 1 goes the first time through the finish.
- The finish display (7) shows the run time of start number 1 for a few seconds (depending on the adjusted display time 1 in menu 4), then it shows again the running time. Display (8) shows still start number 1, but the lap counts up to 2.
- etc.
- Start number 1 goes the second time through the finish.
- The finish display (7) shows the run time of start number 1 for a few seconds (depending on the adjusted display time 1 in menu 4), then it shows again the running time. Display (8) shows still start number 1, but the lap counts up to 3.
- etc.
- Start number 1 goes the third time through the finish.
- The finish display (7) shows the run time. Display (8) shows still start number 1, and lap 3.
- etc.

Lap Time Correction:

You cannot correct a lap time direct. A lap time will be corrected, when you correct a time of day of channel 0 or 1, or a run time.

Timing Channels:

c0 = start channel c2 = intermediate time c4 = intermediate time c6 = intermediate time c8 = intermediate time
 c1 = finish channel c3 = intermediate time c5 = intermediate time c7 = intermediate time c9 = intermediate time

ALGE adjustment for the main menu:

Menu 1: Delay Time Start = 1.00 s	Menu 14: Print Menus = ON
Menu 2: Delay Time Finish = 0.30 s	Menu 15: Print Linefeeds = 0
Menu 3: Seconds Mode = OFF	Menu 16: RS-232 Baudrate = 9600 Bd
Menu 4: Display Time 1 = 03 s	Menu 17: RS-232 Run time = OFF

- Menu 5: Display Time 2 = 03 s
- Menu 6: Display Thousandth = OFF
- Menu 7: Info-Display = START
- Menu 8: Running Time = RUN
- Menu 10: Intermediate Rank = ON
- Menu 11: Finish Rank = ON
- Menu 12: STNO Automatic = OFF
- Menu 13: Print Start Time = OFF

- Menu 18: RS-232 Baud rate = 2400
- Menu 19: D-Board Channel 2 = RUNNING
- Menu 20: Beep = ON
- Menu 21: Handicap time = 00:00:00.00
- Menu 22: Groups = OFF
- Menu 23: Change Run
- Menu 24: Change Race
- Menu 25: D-Board-Test

Printer:
Heat 1:

Printing example

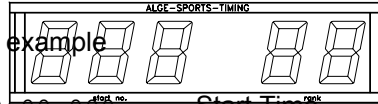

0001 ST 10:00:00.000 Start Time
FT 10:10:20.234 Finish Time

RT 10:20.2 Run Time
1 SQ 10:20.2 Lap Time of the 1st Lap

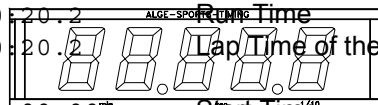

0001 ST 10:00:00.000 Start Time
FT 10:20:39.334 Finish Time

RT 20:39.3 Run Time
2 SQ 10:19.1 Lap Time of the 2nd Lap



Heat 2:

0001 ST 14:00:00.000 Start Time
FT 14:11:20.541 Finish Time

RT 11:20.5 Run Time
1 SQ 11:20.5 Lap Time of the 1st Lap

MT 20:39.3 Memory Time (of the 1st heat)
TT 31:59.8 Total Time (time of the 1st heat plus run time of the 2nd heat)

0001 ST 14:00:00.000 Start Time
FT 14:22:00.401 Finish Time

RT 22:00.4 Run Time
2 SQ 10:49.9 Lap Time of the 2st Lap

MT 20:39.3 Memory Time (of the 1st heat)
TT 42:39.7 Total Time (time of the 1st heat plus run time of the 2nd)

Display Board GAZ4:

You can show on different display boards:

start number and rank, running time and run time, and lap time (sequential time)

In the main menu (menu 19, see page 56) it is possible to activate display board channel 2 . If you activate channel 2 it shows only the run times, but not the running time on the display board.

start number / rank:

thumb wheel switch on 0 toggle switch upper position

time:

thumb wheel switch on 0 toggle switch middle position

lap time (sequential):

thumb wheel switch on 1 toggle switch middle position

RS 232 interface: see on page 96, chapter 8.2

Output of all time of day, like for the SPLIT program. If you want the output of the calculated times as well you have to select it in the Menu "RS232 Run Time = on"

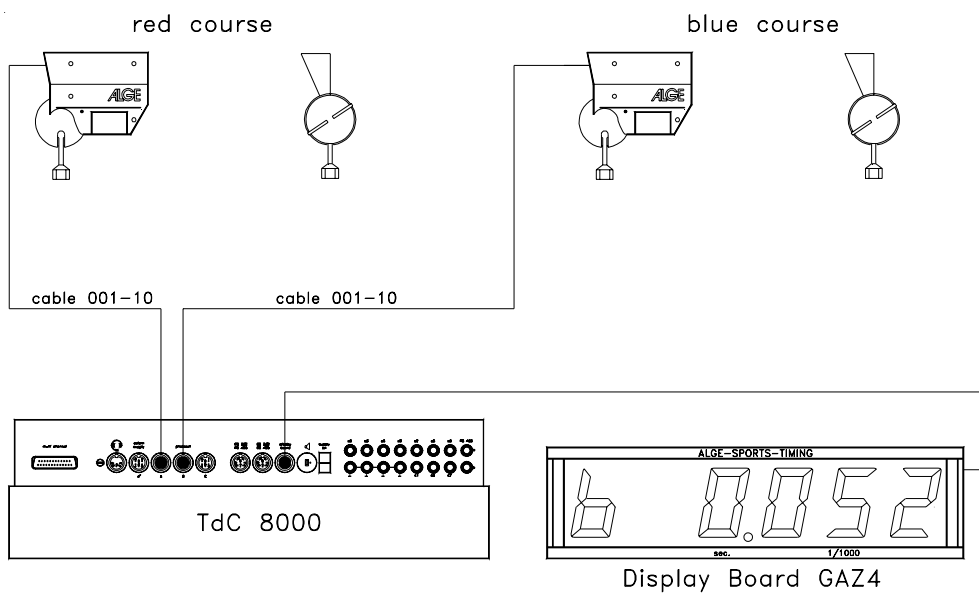

6.2. Parallel Slalom:

6.2.1. Parallel Diff. (Parallel Slalom with Finish-Difference-Time):



Program 4

- Each competitor pair gets a run number (counts automatic up from 1 to 9999).
- In the finish you need two photocells, one for the red course, one for the blue.
- The first photocell impulse starts the timing, the second stops the time.
- The display (7) shows the finish difference time and the winner course (b = blue, r = red).
- A cable from the start to the finish is for this timing mode not necessary.
- Connect the photocell of the red course on channel 1 (cable 001-10 on socket 19 or 20).
- Connect the photocell of the blue course on channel 4 (cable 001-10 on socket 21).

Adjustment:

- Switch TdC 8000 on (switch 26)
- Select program PARALLEL SLALOM WITH FINISH-DIFFERENCE-TIME with cursor key (↓ and ↑)
- Press <ENTER>
- Select race that you want to use and clear memory (e.g. <F1> for race 1)
- Press <ENTER>
- Select race (e.g. <F1> for race 1)
- Press <ENTER>
- Synchronize the TdC 8000 (with time of day and other timing devices)
 - Press <F1> if the finish display (7) shows the correct time of day
 - Wait until TdC gives at the next full minute the synchronize signal to external devices
 - The TdC 8000 is now ready for timing
 - Press <F2> if the finish display (7) shows the wrong time of day
 - Input the time of day with the finish keyboard (15), and confirm it with <ENTER>
 - Start the clock with a start signal (channel 0 or press <START> key)
 - The TdC 8000 is now ready for timing

Race operation:

- Switch (1) in upper position. 
- Display (2) and (8) show automatically run number 1.
- If you want to input another run number input it with keyboard (9) or (15) and confirm it with <ENTER>.
- Display (2) and (8) must show the correct run number
- Display (7) shows the time 0:000
- Press <ALT> and <MENU> together to get into the main menu. 
- Input 26 with finish keyboard (15).
- It shows now menu 26 and you can check the penalty time.
 - If the penalty time is correct, press <ALT> and <MENU> together to leave the main menu.
 - If the penalty time is not correct press <YES>
 - Input the penalty time with the finish keyboard (15).
 - Confirm the penalty time with <ENTER>
 - Leave the main menu by pressing <ALT> and <MENU> together.
- The TdC 8000 is not connected to the start and therefore does not get a start signal.
- Display (7) shows the running finish-difference-time and the identification of the winning course, when the first competitor goes through the finish.
- Display (7) shows the finish-difference-time and the identification of the winning course.
- Press <ENTER> to increase the run number for the next race.
- Display (2) and (8) must show the next run number.
- Display (7) shows the time 0:000
- etc.

Penalty Time:

The penalty time is used as finish difference time, if somebody fails to finish the first heat. If you want to work without penalty time input 0.000 as penalty time.

If one competitor comes through the finish it shows the running time in the display (7) and on the display board until the second competitor comes through the finish. If the second competitor does

not reach the finish or reaches the finish after the penalty time is over, it shows on the display (7) and display board the penalty time. It marks the penalty time on the printer with "P". You can input the penalty time in the main menu in menu 27 (see page 59).

Clear Finish Times:

If you press the key <CLEAR> of the start keyboard (9) or finish keyboard (15), it clears the finish impulses. I clears the finish impulse of the red and blue course, if both finished before you press <CLEAR>.

Deactivate the Impulse Channels (<BLOCK>):

You can deactivate each course separate.

If you press <BLOCK> of the start keyboard (9), it prints the time of the blue course (c4) as a non valid time. If you press <BLOCK> of the finish keyboard (15), it prints the time of the red course (c1) as a non valid time. If you press <ALT> and <BLOCK> at the same time, it does not take the time of that impulse.

Timing Channels:

c0 = no function c2 = no function c4 = finish channel blue c6 = no function c8 = no function
c1 = finish channel red c3 = no function c5 = no function c7 = no function c9 = no function

ALGE adjustment for the main menu:

- Menu 2: Delay Time Finish = 0.30 s
- Menu 3: Seconds Mode = OFF
- Menu 4: Display Time 1 = 03 s
- Menu 9: Running Tenth = OFF
- Menu 12: STNO Automatic = OFF
- Menu 14: Print Menus = ON
- Menu 15: Print Lineds = 0
- Menu 16: RS-232 Baudrate = 9600 Bd

- Menu 17: RS-232 Run time = OFF
- Menu 18: D-Board Baudrate = 2400 Bd
- Menu 19: D-Board Channel 2 = RUNNING
- Menu 20: Beep = ON
- Menu 24: Change Race
- Menu 25: D-Board-Test
- Menu 26: ID channel = b (blue)
- Menu 27: Penalty Time

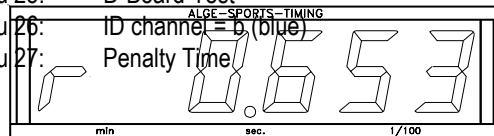

Display:

- Display (2) and (6) shows the run number.
- Display (7) shows the finish difference time and winners course
- The Info-Display (6) has no function for the parallel slalom timing.

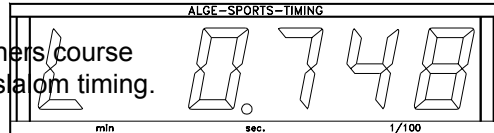

Printer:



0001	r	-	1.231	run number 1:	red course wins with 1.231 sec. advance
0002	b	-	0.429	run number 2:	blue course wins with 0.429 sec. advance
P0003	b	-	1.500	run number 3:	blue course wins with 1.500 sec. advance
?0003	C1	10:15:34.	237	run number 3:	not valid impulse
0004	r	-	0.217	run number 4:	red course wins with 0.217 sec. advance
c0004	r	-	0.217	run number 4 is	cleared

Photocells for the Finish:

- Connect the photocell for the red course at the TdC 8000:
For cable 001-10, 001-20, or 001-30 use socket A'(19) or A (20).
If you have an external supply for the photocell, it is possible to use a 2-wire cable. Connect this cable at channel c1 (27).
- Connect the photocell for the blue course at the TdC 8000:
For cable 001-10, 001-20, or 001-30 use socket B (21).
If you have an external supply for the photocell, it is possible to use a 2-wire cable. Connect this cable at channel c4 (27).

Display Board GAZ4:

You can show the finish-difference-time and the winner course on a display board (b= blue, r=red).

In the main menu (menu 26, see on page 59) you can adjust, if it should show for the winner course red (r) and blue (b), or right (r) and left (L).

In the main menu (menu 19, see on page 56) it is possible to activate display board channel 2. If you activate channel 2 it shows only the run times on the display board.

Transfer Format: 1 start bit, 8 data bit, no parity bit, 1 stop bit
Transfer Speed: 2.400 Baud
Transfer Protocol: ASCII

NNNPxxxxxxxxx : Sz : ht (CR)	standing time before a runner reaches the finish
NNNPxxxxxxxxbS : Sxxxx (CR)	running finish difference time (blue course wins, without 1/10)
NNNPxxxxxxxx§S : Sxxxx (CR)	running finish difference time (r course wins, without 1/10)
NNNPxxxxxxxx\$S : Sxxxx (CR)	running finish difference time (left course wins, without 1/10)
NNNPxxxxxxxxbS : Szxxx (CR)	running finish difference time (blue course wins, with 1/10)
NNNPxxxxxxxx§S : Szxxx (CR)	running finish difference time (r course wins, with 1/10)
NNNPxxxxxxxx\$S : Szxxx (CR)	running finish difference time (left course wins, with 1/10)
NNNPxxxxxxxxbS : Sz ht (CR)	finish difference time (blue course wins)
NNNPxxxxxxxx§S : Sz ht (CR)	finish difference time (r course wins)
NNNPxxxxxxxx\$S : Sz ht (CR)	finish difference time (left course wins)

x..... blank
 NNN run number
 P identification for parallel slalom
 §..... r (red/right) course (0A Hex.; always character 12)
 \$..... L (left) course (0C Hex.; always character 12)
 b..... b (blue) course (always character 12)
 S seconds (on ten digit it does not show a zero)
 z..... 1/10 seconds
 h..... 1/100 seconds
 t..... 1/1000 seconds
 (CR) Carriage Return

Output through the RS 232c interface:

Transfer Format: 1 start bit, 8 data bit, no parity bit, 1 stop bit
Transfer Speed: 9.600 Baud pre adjusted (adjustable: 2400, 4800, 9600)
Transfer Protocol: ASCII

xNNNNxC4xxHH : MM : SS . zhtqxxxxxxxx (CR)
 xNNNNxC1xxHH : MM : SS . zhtqxxxxxxxx (CR)
 ?NNNNxC4xxHH : MM : SS . zhtqxxxxxxxx (CR)
 ?NNNNxC1xxHH : MM : SS . zhtqxxxxxxxx (CR)

cNNNNxC4xxHH:MM:SS.zhtqxxxxxxxx (CR)
cNNNNxC1xxHH:MM:SS.zhtqxxxxxxxx (CR)

The following string will be only sent if you have the following setting in the main menu:

Menu 16: RS 232 run time = on

xNNNNxrxxxHH:MM:SS.zht (CR)
xNNNNxbxxxHH:MM:SS.zht (CR)
xNNNNxlxxxHH:MM:SS.zht (CR)
cNNNNxrxxxHH:MM:SS.zht (CR)
cNNNNxbxxxHH:MM:SS.zht (CR)
cNNNNxlxxxHH:MM:SS.zht (CR)

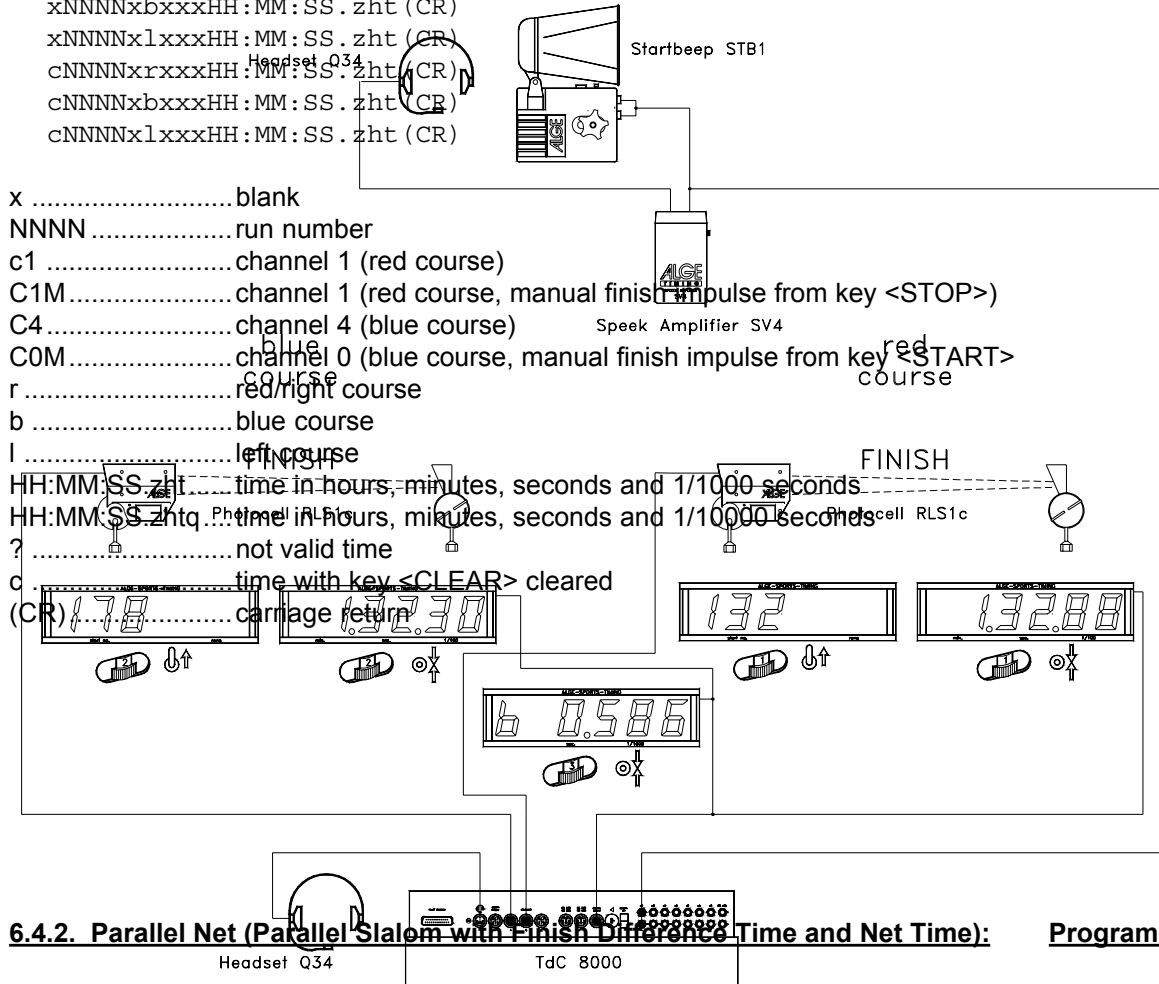

Parallelsalom with the possibility to measure the run times and difference time. It is possible to measure both runs. In this case you will get the run times, total times, the difference time of the run, and the total difference time.

Adjustment:

- Switch TdC 8000 on (switch 26)
- Select program PARALLEL NET with cursor key (**←** and **→**)
- Press <ENTER>
- Select race that you want to use and clear memory (e.g. <F1> for race 1)
- Press <ENTER>
- Select race (e.g. <F1> for race 1)
- Press <ENTER>
- Select precision (e.g. <F4> for 1/1000 precision)
- Press <ENTER>
- Synchronize the TdC 8000 (with time of day and other timing devices)
 - Press <F1> if the finish display (7) shows the correct time of day
 - Wait until TdC gives at the next full minute the synchronize signal to external devices
 - The TdC 8000 is now ready for timing
 - Press <F2> if the finish display (7) shows the wrong time of day
 - Input the time of day with the finish keyboard (15), and confirm it with <ENTER>
 - Start the clock with a start signal (channel 0 or press <START> key)
 - The TdC 8000 is now ready for timing

Race operation:

- Input start number for the blue (left) course with keyboard (9), e.g. StNo. 1.
- Press <ENTER>.
- Display (2) must show the start number of the blue (left) course.
- Input start number for the red (right) course with keyboard (15), e.g. StNo. 2.
- Press <ENTER>.
- Display (8) must show the start number of the red (right) course.
- The Info-Display (6) shows the start number and time of the blue (left) and red (right) course.
- Start the first pair of competitors (channel c0 or c1, the start key does not work).
- Display (2) and (8) shows the start number and "u" (= used).
- The info display (6) shows the start number of the blue (left) and red (right) course as well as the running times.
- Finish impulse for start number 1.
- Finish impulse for start number 2.
- The info-display (6) shows the start number and run time of the blue (left) and red (right) course, as well as the difference time next to the winners time.
- You can input the start numbers of the next competitors as before.
- etc.

Race operation for the 2nd heat:

Change Race:

- All races for the 1st heat must be finished.
- Press <ALT> and <MENU> at the same time.
- Input number 23 with finish keyboard (15).
- The info-display (6) shows now "CHANGE HEAT".
- Press <YES> to confirm.
- Press <F2> to select the next heat.
- Press <ENTER> to confirm, now it changes to the new heat.

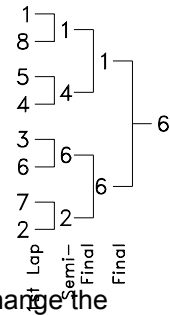

In the 2nd heat you have the same start numbers competing each other, but they change the course.

The racer that had in the first heat the red course takes for the 2nd heat the blue course, and the vice versa.

If you input a start number for the correct slope it shows you automatically the right second start number.

Make sure that you have set menu 8 on "RUNNING TIME = RUN".

- Input start number for the blue (left) course with keyboard (9), e.g. StNo. 2.
- Press <ENTER>.
- It shows the correct start number for the red (right) course automatically, e.g. StNo. 1.
- Display (2) shows the start number of the blue (left) course.
- Display (8) shows the start number of the red (right) course.
- The Info-Display (6) shows the start number and time of the blue (left) and red (right) course.
- Next to the winner of the first heat it shows the difference time from the first heat.
- Start the first pair of competitors (channel c0 or c1, the start key does not work).
- Display (2) and (8) shows the start number and "u" (= used).
- The info display (6) shows the start number of the blue (left) and red (right) course as well as the running times.
- Finish impulse for start number 1.
- Finish impulse for start number 2.
- The info-display (6) shows the start number and run time of the blue (left) and red (right) course, as well as the difference time next to the winners time.
- When the display time 1 finish it shows the total time of each competitor and the total difference time.
- You can input the start numbers of the next competitors as before.
- etc.

Further Laps:

Each time when a competitor meets another competitor it is considered as a new lap. This means in the first lap e.g. number 1 meets number 8, and number 5 meets number 4. After the second heat reaches the competitor with the faster total run time the next lap.

Before you start a new lap, it is necessary to confirm it with the TdC 8000.

Change to menu 23 and confirm "CHANGE HEAT" and "NEXT".

Tastenfunktionen:

	<i>blue (left)</i> <i>(keyboard 9 or 14)</i>	<i>red (right)</i> <i>(keyboard 15 or 14)</i>
clear finish time:	CLEAR	CLEAR
recall finish time:	ALT + CLEAR	ALT + CLEAR
not valied finish times:	BLOCK	BLOCK
ignore finish times:	ALT + BLOCK	ALT + BLOCK
no function	INPUT	INPUT
no function	MENU + INPUT	MENU + INPUT
no function	F1	F1
no function	F2	F2
no function	F3	F3

change between run time and total time
 no function

F4
 CLASS.

F4
 CLASS.

Penalty Time:

The penalty time is used as finish difference time, if somebody fails to finish the first heat. If you want to work without penalty time input 0.000 as penalty time.

If one competitor comes through the finish the difference time starts to run, until the second competitor comes through the finish. If the second competitor does not reach the finish or reaches the finish after the penalty time is over, it shows on the display (7) and on the display board the penalty time. It marks the penalty time on the printer with "P".

You can input the penalty time in the main menu in menu 27 (see page 59).

Clear Finish Times:

Each course has a <CLEAR> key.

<CLEAR> from keyboard (9) blue (left) course

<CLEAR> from keyboard (15) red (right) course

With <CLEAR> you clear the last impulse of the time of appropriate course. This means if you press <CLEAR> after the start, it will set the time back to zero. If you press <CLEAR> after the racer reaches the finish, it will show the running time again. If you press again <CLEAR> it will clear also the start time.

By pressing <ALT> and <CLEAR> it makes the last cleared time valued.

If you use a penalty time (menu 27) it shows you automatically after clearing a finish time a new time calculated with the penalty time (when the other course has already a finish time).

Block Finish Times:

You can block the finish time of each course separate.

If you press <BLOCK> of keyboard (9) it prints the finish time (c1) of the blue (left) course as a not valid time with a question-mark (?).

If you press <BLOCK> of keyboard (15) it prints the finish time (c4) of the red (right) course as a not valid time with a question-mark (?).

If you press <ALT> and <BLOCK> together, it will not take the finish impulse of the course at all.

Changing Times: <INPUT> has no function!

Classement: <CLASS> has no function!

Course Identification:

It identifies the courses with b (= blue) and r (= red), or l (= left) and r (= right). You can select in the main menu if you want the identification b or L (Menu 26: ID CHANNEL 4).

Photocells for the Finish:

- the red (right) course must be connected with channel 1 (cable 001-10 at socket 20)
- the blue (left) course must be connected with channel 4 (cable 001-10 at socket 21)

Photocells for the First Intermediate Time:

- the red (right) course must be connected with channel 2.
- the blue (left) course must be connected with channel 5.

Photocells for the Second Intermediate Time:

- the red (right) course must be connected with channel 6.
- the blue (left) course must be connected with channel 7.

Photocells for the Third Intermediate Time:

- the red (right) course must be connected with channel 8.
- the blue (left) course must be connected with channel 9.

Timing Channels

c0 = Start (= C3) c2 = Intermed. 1 red c4 = Finish, blue c6 = Intermed. 2 red c8 = Intermed. 3 red
 c1 = Finish, red c3 = Start (= C0) c5 = Intermed. 1 blue c7 = Intermed. 2 blue c9 = Intermed. 3 blue

ALGE adjustments for the main menu:

Menü 1: Delay Time Start = 1.0 s	Menü 16: RS-232 Baudrate = 9600 Baud
Menü 2: Delay Time Finish = 0.3 s	Menü 17: RS-232 Run time = off
Menü 3: Seconds Mode = off	Menü 18: D-Board Baudrate = 2400 Baud
Menü 4: Display Time1 = 3 s	Menü 19: D-Board Kanal 2 = running
Menü 5: Display Time 2 = 3 s	Menü 20: Beep = on
Menü 8: Running Time = run	Menü 24: Change Heat
Menü 9: Running Tenth = off	Menü 24: Change Race
Menü 13: Print Start Time = off	Menü 25: D-Board-Test = off
Menü 14: Print Menues = on	Menü 26: ID Channel 4 = b (blue)
Menü 15: Print Linefeed = 0	Menü 27: Penalty Time = 1.500 Sek.

Display (2):

Shows the start number of the blue (left) course. Additional it shows the position of switch (1) and the condition of the competitor (no identification = not started, "u" = used or started, r = run time, t = total time (only in the 2nd heat)).

Display (8):

Shows the start number of the red (right) course. Additional it shows the position of switch (1) and the condition of the competitor (no identification = not started, "u" = used or started, r = run time, t = total time (only in the 2nd heat)).

Info-Display (6):

The info-display shows the actual start numbers and the times. After the racer finish their race it shows as well the difference time.

0001 b	0:00.000		before the start:
0002 r	0:00.000		StNo, course (b = blue, r= red), time
0001 b	0:03		after the start:
0002 r	0:03		StNo, course (b = blue, r= red), running time
0001 b RT	0:44.206		After the finish (1st heat):
0002 r RT	0:44.160	-0.046	StNo, course, RT, run time, difference time
0002 b	0:00.000	-0.046	Before the start of the 2nd heat:
0001 r	0:00.000		StNo, course , time, advantage from run 1
0002 b RT	0:44.298	-0.025	After the finish (2nd heat):
0001 r RT	0:44.323		StNo, course, RT, run time, difference time run
0002 b TT	1:28.458	-0.071	After the finish (2nd heat):
0001 r TT	1:28.529		StNo, course, TT, Totaltime, difference time total

You can switch with **<F4>** between run time and total time in the 2nd heat after a racer reached the finish and the end of the display time.

Printer: Printing examples

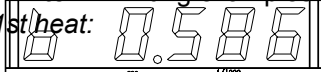
1st heat: 
 0002rST 10:00:00.121
 FT 10:00:44.281
 RT 0:44.160

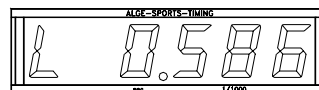

start time, red course, StNo 2
 finish time, red course, StNo2
 run time, red course, StNo2

0001bST 10:00:00.121
 FT 10:00:44.327
 RT 0:44.206
 0002rDTR - 0.046

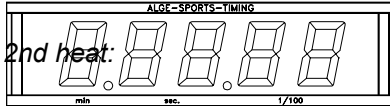

0002bST 10:30:10.001
 FT 10:30:54.299
 RT 0:44.298
 MT 0:44.160

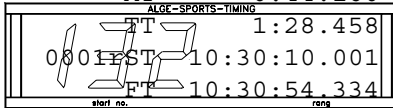

RT 0:44.323
 MT 0:44.206
 TT 1:28.529
 0002bDTR - 0.025
 0002bDTT - 0.071

start time, blue course, StNo1
 finish time, blue course, StNo1
 run time, blue course, StNo1
 difference time of the run, advantage of red course (StNo. 2)



start time, blue course, StNo 2
 finish time, blue course, StNo2
 run time, blue course, StNo2
 memory time, blue course, StNo 2

total time, blue course, StNo 2
 start time, red course, StNo1
 finish time, red course, StNo1
 run time, red course, StNo1

memory time, red course, StNo 1
 total time, red course, StNo 1
 difference time of the run, advantage of blue course (StNo 2)
 total difference time, advantage of blue course (StNo 2)



Display Board GAZ4:

Difference Time (Run and Total):

It shows the course identification b (= blue or L = left) or r (= red or right) on the first digit of a six digit ALGE display board. Then it shows the time in 1/1000 of seconds. The course identification you can set in menu 26.

red course

right course

blue course

left course

Menu 26: ID channel 4 = b

Menu 26: ID Channel 4 = L

Runtime / Totaltime:

Each course needs a separate display board. Each board shows the time in minutes, seconds, and 1/100 seconds.

red (right) course

blue (left) course

Start Number:

Each course needs a separate display board. It shows the start number on three digits.

red (right) course

blue (left) course

RS 232c Interface (23):

Transfer Format:

1 Start Bit, 8 Data-Bit, no Parity-Bit, 1 Stop Bit

Transfer Speed:

9.600 Baud pre adjusted (adjustable: 2400, 4800, 9600)

Transfer Protocol: ASCII

xNNNNiCCxxHH:MM:SS.zhtqx## (CR) Parallelsalom, Intermediate Time or Finish Time

xNNNNiRTxxHH:MM:SS.zhtqx## (CR) Parallelsalom, Run Time
 xNNNNiDTRxxHH:MM:SS.zhtxx## (CR) Parallelsalom, Difference Time of Run
 xNNNNiTTxxHH:MM:SS.zhtqx## (CR) Parallelsalom, Total Time
 xNNNNiDTTxxHH:MM:SS.zhtxx## (CR) Parallelsalom, Total Difference Time
 pNNNNiCCxxHH:MM:SS.zhtqx## (CR) Parallelsalom, Finish Time calculated form Penalty Time
 pNNNNiRTxxHH:MM:SS.zhtqx## (CR) Parallelsalom, Run Time calculated form Penalty Time
 pNNNNiTTxxHH:MM:SS.zhtqx## (CR) Parallelsalom, Total Time calculated form Penalty Time

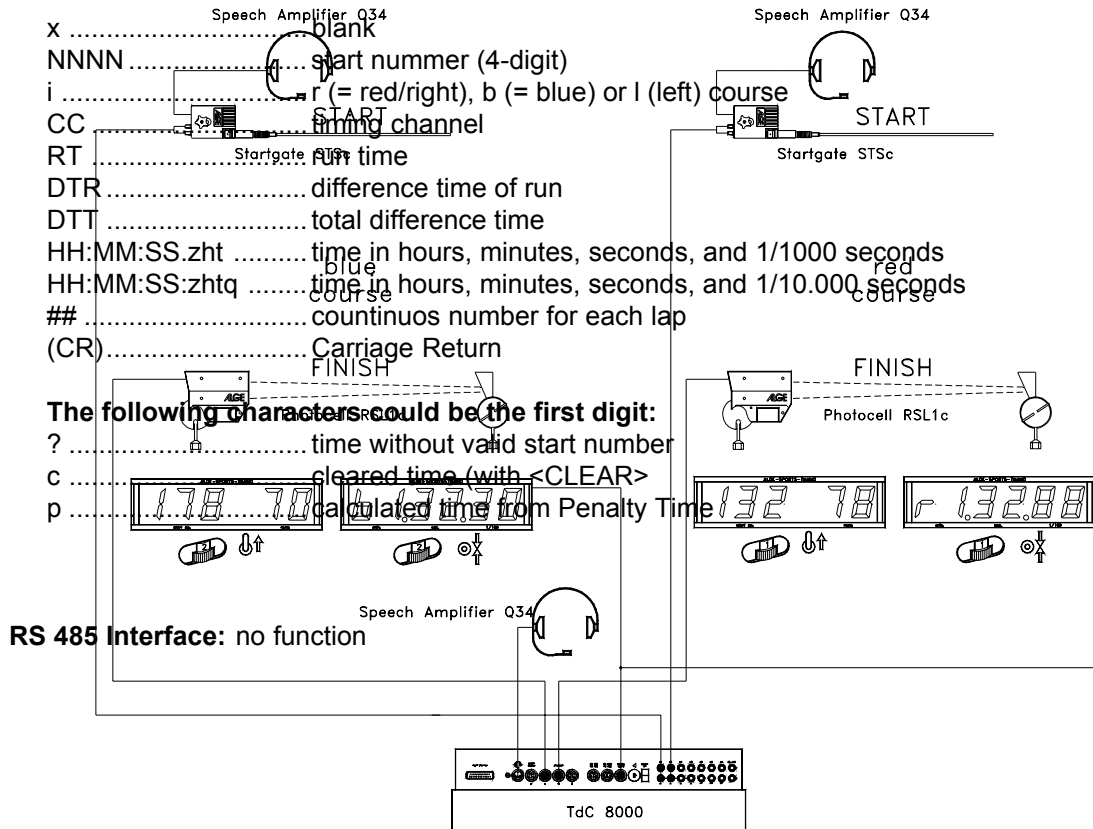

6.5. Dual Timer

Program 6

Net timing with intermediate times on two courses. Each slope can have one racer on course. You can select between a common or separate start impulse for both courses.

This porgram works only for one heat.

Adjustment:

- Switch TdC 8000 on (switch 26)
- Select program DUAL TIMER with cursor key (⏪ and ⏩)
- Press <ENTER>
- Select race that you want to use and clear memory (e.g. <F1> for race 1)
- Press <ENTER>
- Select race (e.g. <F1> for race 1)
- Press <ENTER>
- Select precision (e.g. <F3> for 1/100 precision)
- Press <ENTER>
- Press <YES> if you want to input groups for the race, otherwise <NO> or <ENTER>
 - if you input the groups input always the last start number within a group
 - confirm each start number with <ENTER>
 - after the start number of the last group you must press <ENTER> twice
- Synchronize the TdC 8000 (with time of day and other timing devices)
 - Press <F1> if the finish display (7) shows the correct time of day
 - Wait until TdC gives at the next full minute the synchronize signal to external devices
 - The TdC 8000 is now ready for timing
 - Press <F2> if the finish display (7) shows the wrong time of day
 - Input the time of day with the finish keyboard (15), and confirm it with <ENTER>
 - Start the clock with a start signal (channel 0 or press <START> key)
 - The TdC 8000 is now ready for timing



Race operation:

- Switch (1) has no function.
- Input start number for the blue (left) course with keyboard (9), e.g. StNo. 1.
- Press <ENTER>.
- Display (2) must show the start number (and group) of the blue (left) course.
- Input start number for the red (right) course with keyboard (15), e.g. StNo. 2.
- Press <ENTER>.
- Display (8) must show the start number (and group) of the red (right) course.
- The Info-Display (6) shows the start number and time of the blue (left) and red (right) course.
- If you press <ALT> and <MENU> together, you can select in Menu 28, if the start is separate for both courses, or if you have only one start impulse to start both courses (e.g. Menu 28: Start Channel = separate).
- Start impulse for start number 1.
- Start impulse for start number 2.
- The info-display (6) shows the start number and running time of both courses.
- Finish impulse for start number 1.
- Finish impulse for start number 2.
- The info-display (6) shows the start number and run time of the blue (left) and red (right) course.
- You can input the start numbers of the next competitors as before.
- etc.



Clear Finish Times:

By pressing <CLEAR> of keyboard (9) it clears the finish impulse of the blue (left) course. If you press <ALT> and <CLEAR> together it gives you the cleared time back. By pressing <CLEAR> of keyboard (15) it clears the finish impulse of the red (right) course. If you press <ALT> and <CLEAR> together it gives you the cleared time back.

Block Finish Times:

You can block the finish time of each course separate. If you press <BLOCK> of keyboard (9) it prints the finish time (c1) of the blue (left) course as a not valid time with a question-mark (?). If you press <BLOCK> of keyboard (15) it prints the finish time (c4) of the red (right) course as a not valid time with a question-mark (?). If you press <ALT> and <BLOCK> together, it will not take the finish impulse of the course at all.

Changing Times:

You can copy a time from one start number to another, you can make a not valid time

valid, or you can input a manual time. With the <INPUT> key of the keyboard (9) you change times of the blue course, with the <INPUT> key of the keyboard (15) you change times of the red course.

- Change the finish times with <INPUT>.
- Change the start times with <ALT> and <INPUT>.
- Change the run times and intermediate times with <MENU> and <INPUT>.

Classement:

You can print a classement for both courses together, or only for the blue (left) or red (right) course.

Ranking:

You can make the ranking for both courses together or separate. The adjustment for that features are in the main menu (menu 29: rank calculation).

Start Channel:

You can use one start channel (c1 or c3) for both courses together (parallel start) or separate c1 for the red (right) course and c3 for the blue (left) course. The adjustment for that features are in the main menu (menu 28: start channel).

Course Identification:

You can select if you want as course identification r (= red) and b (= blue) or r (= right) and l (= left). The adjustment for that features are in the main menu (menu 27: ID channel).

Timing Channels:

- | | |
|---|---|
| c0 = Start channel red (right) | c5 = Intermediate channel 1 blue (left) |
| c1 = Finish channel red (right) | c2 = Intermediate channel 2 red (right) |
| c2 = Intermediate channel 1 red (right) | c7 = Intermediate channel 2 blue (left) |
| c3 = Start channel blue (left) | c2 = Intermediate channel 3 red (right) |
| c4 = Finish channel blue (left) | c9 = Intermediate channel 3 blue (left) |

ALGE adjustment for the main menu:

- Menu 1: Delay Time Start = 1.00 s
- Menu 2: Delay Time Finish = 0.30 s
- Menu 3: Seconds Mode = OFF
- Menu 4: Display Time1 = 03 s

- Menu 5: Display Time 2 = 03 s
- Menu 6: Display Thousandth = OFF
- Menu 8: Running Time = RUN
- Menu 9: Running Tenth = OFF
- Menu 10: Intermediate Rank = ON
- Menu 11: Finish Rank = ON
- Menu 13: Print Start Time = OFF
- Menu 14: Print Menu = ON
- Menu 15: Print Linefeeds = 0
- Menu 16: RS-232 Baudrate = 9600 Bd
- Menu 17: RS-232 Run time = OFF
- Menu 18: RS-232 Baud rate = 2400
- Menu 19: D-Board Channel 2 = RUNNING
- Menu 20: ID = ON
- Menu 21: Handicap time = 00:00:00.00
- Menu 22: Groups = OFF
- Menu 24: Change Race =
- Menu 25: D-Board-Test = 70
- Menu 26: ID channel = 4
- Menu 28: Start Channel = SEPARATE
- Menu 29: Rank Calculation = SEPARATE

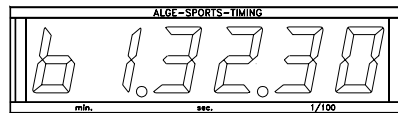
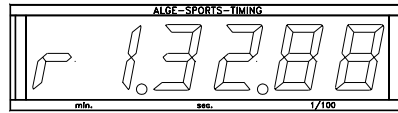
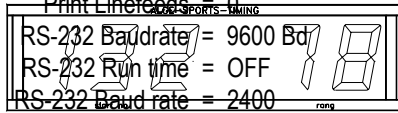

Printer: Printing example

0001bST	10:05:58.990	start time of blue course
FT	10:07:20.234	finish time of blue course
RT	1:21.24	run time of blue course
0002rST	10:07:01.485	start time of red (right) course
FT	10:08:22.385	finish time of red (right) course
RT	1:20.90	run time of red (right) course
0001lST	10:05:58.990	start time of left course (menu 24 set on left)
FT	10:07:20.234	finish time of left course
RT	1:21.24	run time of left course

Display Board GAZ4:

For each course you need separate display boards. You can show the both net times on display boards as well as start number and rank. You must set code switch of the display boards for the red (right) course on 1, for the blue (left) on 2.

In the main menu (menu 19, see page 56) it is possible to activate display board channel 2 . If you activate channel 2 it shows only the run times on the display board.

RS 232 Interface:

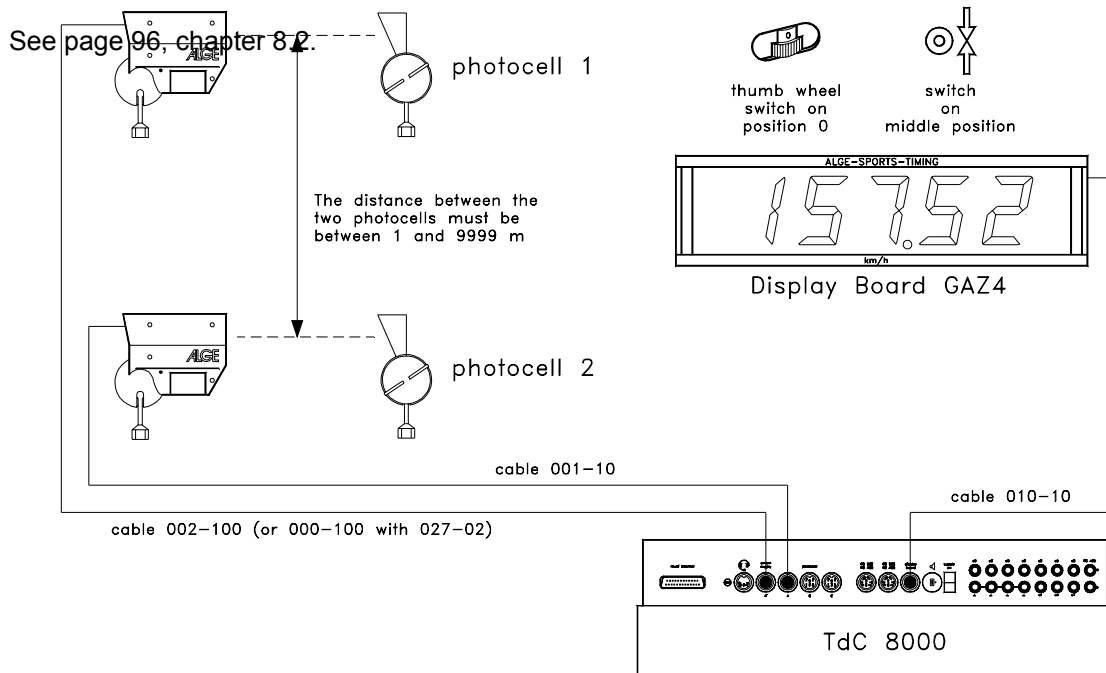

6.6. SPEED



Program 7

You can measure the speed for a selected distance with two photocells (or other impulse devices).

- Measuring Unit: Adjustable in km/h (kilometre per second), m/s (meter pro second), or mph (miles per hour)
- Measuring Distance: Adjustable form 1 to 9999 m (it is always in meter)
- Lowest Speed: Adjustable form 1 to 9999 km/h, m/s, or mph (depending on the adjusted measuring unit)
- Highest Speed: Adjustable form 1 to 9999 km/h, m/s, or mph

(depending on the adjusted measuring unit)

Adjustment:

- Switch TdC 8000 on (switch 26)
 - Select program 7 "SPEED² with cursor key ( and )
 - Press <ENTER>
 - Select race that you want to use and clear memory (e.g. <F1> for race 1)
 - Press <ENTER>
 - Select race (e.g. <F1> for race 1)
 - Press <ENTER>
 - Press <YES> if you want to input groups for the race, otherwise <NO> or <ENTER>
 - if you input the groups input always the last start number within a group
 - confirm each start number with <ENTER>
 - after the start number of the last group you must press <ENTER> twice
- Synchronize the TdC 8000 (with time of day and other timing devices)
- press <F1> if the finish display (7) shows the correct time of day
 - wait until TdC 8000 gives at the next full minute the synchronize signal to external devices (you are now ready for timing)
 - press <F2> if the finish display (7) shows the wrong time of day
 - input the time of day, confirm it with <ENTER> and make a start signal (channel 0 or press <START>

Race operation:

- Switch (1) in upper position
- Press together <ALT> and <MENU>
- Go into menu 31 (Distance) to adjust the measuring distance (e.g. 10 m)
- Go into menu 32 (Measuring Unit) to select the measuring unit (km/h, m/s, or mph)
- Go into menu 33 (min. Speed) to adjust the lowest speed that you want to measure
- Go into menu 34 (max. Speed) to adjust the highest speed that you want to measure
- Adjust in menu 4 (Display Time 1) the time that the speed is shown if you use "StNo Automatic"
- Turn in menu 12 (StNo Automatic) the Startnumber Automatic on START or FINISH, if you want to show the speed only for a limited time.
- Input the start number for the first measurement with keyboard (9) or 15 (e.g. #1)
- Press <ENTER>
- The display (2) and (8) must show the correct start number (and group)

- Display (7) shows 000.00 as speed
- The TdC 8000 receives a impulse form channel C0
- Display (2) shows a r next to the start number; the r indicates an impulse form channel C0
- The TdC 8000 receives a impulse form channel C1
- Display (8) shows a r next to the start number; the r indicates an impulse form channel C1
- Display (7) shows the rank and speed
- If you use the Startnumber Automatic it will increase automatically the start number, when the Display Time 1 is over.

Timing Channels:

c0 = speed channel c2 = no function c4 = no function c6 = no function c8 = no function
 c1 = speed channel c3 = no function c5 = no function c7 = no function c9 = no function

ALGE adjustment for the main menu:

Menu 4: Display Time 1 = 03 s	Menu 20: Beep = ON
Menu 11: Finish Rank = ON	Menu 22: Groups = OFF
Menu 12: STNO Automatic = OFF	Menu 24: Change Race
Menu 14: Print Menus = ON	Menu 25: D-Board-Test = OFF
Menu 15: Print Linefeeds = 0	Menu 30: Print Times = OFF
Menu 16: RS-232 Baudrate = 9600 Bd	Menu 31: Distance = 100 m
Menu 17: RS-232 Run time = OFF	Menu 32: Measuring Unit = km/h
Menu 18: RS-232 Baud rate = 2400	Menu 33: min. Speed = 10 km/h
	Menu 34: max. Speed = 200 km/h

Measuring Distance:

You can select the distance of two photocells (or other impulse devices) between 1 and 9999 m. You must input the measuring distance always in Meter, no matter what measuring unit you use. Adjust the measuring distance in menu 31.

Measuring Unit:

You can select from the following measuring units: km/h kilometre per hour
 mps meter per second
 mph miles per hour

You select the measuring unit in menu 32. If you select a new measuring unit, it changes automatically the minimum and maximum speed to the new unit, and makes the correct speed adjustment.

Printing Times:

Additional to the speed you can print the time if you select in menu 30 "PRINT TIMES" it will print you the time of first impulse, the time of second impulse, and the net time.

Attention: the TdC 8000 measures the time with a precision of 1/10.000 sec., although it prints only the 1/1000th.

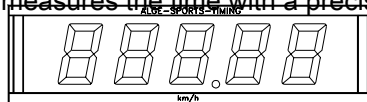

Automatic Speed Measurement:

If you select in menu 12 "StNo Automatic" START or FINISH, it will show every measured speed on the display (7) and display board for the adjusted "Display Time 1" (menu 4). When the Display Time is over, it shows on the display (7) zero, and blank on the display board.

If you select menu 12 "StNo Automatic" OFF, it will show every measured speed until the beginning of the next speed measurement.

Printer: Printing example

Menu 30: Print Times = off:

0001 km/h 144.23 first speed measurement

0002 km/h 120.08 second speed measurement

Menu 30: Print Times = on:

0001 C0	13:49:41.850	1st photocell impulse
0001 C1	13:49:42.100	2st photocell impulse
RT	0:00.249	run time from photocell to photocell
km/h	144.23	first speed measurement
0002 C0	13:59:45.241	1st photocell impulse
0002 C1	13:59:45.541	2st photocell impulse
RT	0:00:195	run time from photocell to photocell
km/h	120.08	second speed measurement

Display Board GAZ4:

You can show the start number and rank, and the speed on different display boards. The display board shows the start number and rank, that is shown in the finish display (8). The display board shows only three digits of start number, and two digits of the rank.

start number / rank:

thumb wheel switch on 0 toggle switch upper position

speed:

thumb wheel switch on 0 toggle switch middle position

RS 232 interface: see on page 96, chapter 8.2

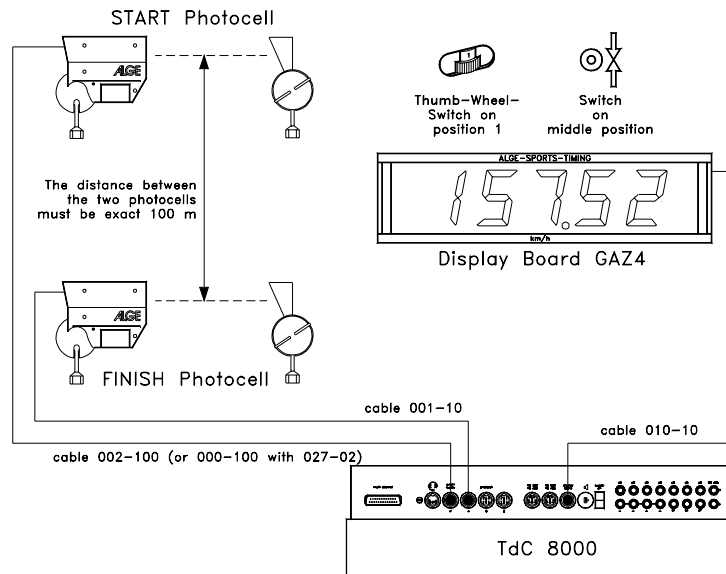

6.7. SPEED SKIING

Program 8

The Speed Skiing program measures the time and speed for skiers passing two photocells set up in a distance of 100 m. The Speed Skiing program works only for one heat.

Measuring Distance: 100 m
(fix adjustment)
Speed: km/h

Timing Channels: (fix adjustment)
C0 Start Channel
C1 Finish Channel

Adjustment:

- Switch TdC 8000 on (switch 26)
- Select program SPEED SKIING with cursor key (↓ and ↑)
- Press <ENTER>
- Select race that you want to use and clear memory (e.g. <F1> for race 1)
- Press <ENTER>
- Select race (e.g. <F1> for race 1)
- Press <ENTER>
- Press <YES> if you want to input groups for the race, otherwise <NO> or <ENTER>
 - if you input the groups input always the last start number within a group
 - confirm each start number with <ENTER>
 - after the start number of the last group you must press <ENTER> twice
- Synchronize the TdC 8000 (with time of day and other timing devices)
 - press <F1> if the finish display (7) shows the correct time of day
 - wait until TdC 8000 gives at the next full minute the synchronize signal to external devices (you are now ready for timing)
 - press <F2> if the finish display (7) shows the wrong time of day
 - input the time of day, confirm it with <ENTER> and make a start signal (channel 0 or press <START>

Race operation:

- Switch (1) in upper position
- Press together <ALT> and <MENU>
- Go into Menu 12 (Start Number Automatic) and select START
- Input the start number for the start with start keyboard (9) (#1)
- Press <ENTER>
- The start-display (2) must show the correct start number (and group)
- Start number 1 starts
- Display (7) shows the running time, display (8) the start number 1
- The start display (2) changes automatically to the next free start number 2
- When the competitor crosses the finish photocell it shows the run time in display (7), and prints the time of days, run time, and speed.
- Start number 2 starts
- Display (7) shows the running time, display (8) the start number 2
- The start display (2) changes automatically to the next free start number 3
- When the competitor crosses the finish photocell it shows the run time in display (7), and prints the time of days, run time, and speed.
- etc.

Timing Channels:

c0 = start channel c2 = no function c4 = no function c6 = no function c8 = no function
c1 = finish channel c3 = no function c5 = no function c7 = no function c9 = no function

ALGE adjustment for the main menu:

- | | |
|------------------------------------|--------------------------------------|
| Menu 1: Delay Time Start = 1.00 s | Menu 14: Print Menu = ON |
| Menu 2: Delay Time Finish = 0.30 s | Menu 15: Print Linefeeds = 0 |
| Menu 3: Seconds Mode = OFF | Menu 16: RS-232 Baudrate = 9600 Bd |
| Menu 4: Display Time 1 = 03 s | Menu 17: RS-232 Run time = OFF |
| Menu 6: Display Thousandth = OFF | Menu 18: RS-232 Baud rate = 2400 |
| Menu 7: Info-Display = START | Menu 19: D-Board Channel 2 = RUNNING |
| Menu 9: Running Tenth = OFF | Menu 20: Beep = ON |

Menu 11: Finish Rank = ON
 Menu 12: STNO Automatic = OFF
 Menu 13: Print Start Time = OFF

Menu 22: Groups = OFF
 Menu 24: Change Race
 Menu 25: D-Board-Test

Printer: Printing example

0001	ST	11:47:59.996	Start Time (photocell 1)
	FT	11:48:02.077	Finish Time (photocell 2)
	RT	0:02.081	Run Time
	SP	km/h 172.99	Speed in km/h
0002	ST	11:48:07.101	Start Time (photocell 1)
	FT	11:48:09.266	Finish Time (photocell 2)
	RT	0:02.165	Run Time
	SP	km/h 166.28	Speed in km/h

Display Board GAZ4:

You can show the net time (running time), the start number and rank, and the speed on different display boards. The display board shows always the start number that is shown in the finish display (8) (on the display board you can show the start number only with three digit and the rank with two digit).

In the main menu (menu 19, see page 56) it is possible to activate display board channel 2. If you activate channel 2 it shows only the run times on the display board.

start number / rank:

thumb wheel switch on 0 toggle switch upper position

time:



thumb wheel switch on 0 toggle switch middle position

speed:

thumb wheel switch on 1 toggle switch middle position



RS 232 interface: see on page 96, chapter 8.2

6.8. TdC TEST:

Program 3

Test program for TdC 8000. It is possible to make measurements of the device, as well as tests with the displays and keyboard. This test is used for the producer to check some functions of the TdC 8000 after the production. It has no function for the normal operation.

Starting the TdC Test:

- Switch TdC 8000 on (switch 26)
- Select program TdC TEST with the cursor keys  and 

- Press <ENTER>
- The info-display (6) shows:

Menu 35: COMMON MEASUREMENTS

Select: YES/NO or menu number: 29

- Select program with the cursor keys **↓** and **↑**:
 - o Common Measurements Menu 29
 - o Display Test Menu 30
 - o Keyboard Test Menu 31
- Confirm selection with <ENTER>

Common Measurements: Menu 35

If you select the common measurements the info-display (6) shows the following:

Menu 36: COMMON MEASUREMENTS	BATT	F1	<F1> checking battery
UB= 8.5V IB=+0.00A TB=+23.9°	CLOCK	F2	<F2> clock of RS-485
UE= 5.0V IE=+0.00A TL=-69.5°	PRINTER	F3	<F3> printer test
Continue: ENTER	SPEAKER	F4	<F4> speaker test

The info-display (6) shows in the second line the battery voltage (UB), the battery current (IB), and the battery temperature (TB).

The third line shows the stabilized external voltage (UE) which should be about 5 V, the current output IE for extender devices, which must be below 1 A, and the TL measurement. The TL measurement is not activated yet and can show any figure.

Press <F1> to check the battery:

The second line of the info-display shows the battery voltage (UB), the battery current (IB), and the battery temperature (TB).

- Press <F1> until the info-display (6) shows at the right upper corner BATT L<. This means that it loads now the battery, if you have the charging device NLG8 connected. The battery current IB must show now a amount of about +2 A.
- Press <F1> until the info-display (6) shows at the upper corner BATT E<. This means that it unloads now the battery. The battery current must have now a value of about -1,6 A.

You can check the CLOCK impulse for the RS-485 interface if you press <F2>. Therefore you need an oscillograph.

If you press <F3> it prints all characters of the printer.

If you press <F4> the external speaker will honk.

Display Test: Menu 36

If you select the display test the info-display (6) shows the following:

Menu 37: DISPLAY TEST	DISPLAY 1	F1	<F1>: check of display (2)
	DISPLAY 2	F2	<F2>: check of display (7)
	DISPLAY 3	F3	<F3>: check of display (8)
Continue: ENTER	DISPLAY 4	F4	<F4>: check of display (6)

To check the numeric display (2, 7, 8) press <F1>, <F2>, and <F3>:

- if you press the <F>-key the first time it writes segment by segment of the display.
- if you press the <F>-key again it shows all segments

- if you press the <F>-key again it makes the display blank.
- To check the alphanumeric info-display (6) press <F4>:
- if you press <F4> it shows the display blank
 - if you press <F4> again it shows all dots of the display
 - if you press <F4> again it shows again Menu 2

Keyboard Test: Menu 37

If you select the keyboard test the info-display (6) shows the following:

```

Menu 38: KEYBOARD TEST
  U SCB 123 YFU TFC SCB
  M 789 IOE NFD MAM 789 IOE
  D 456 * 456
  
```

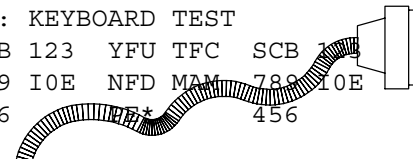

You can check all keys. If you press a key it disappears on the display. If you press the keyboard in the right order the cursor jumps from key to key. Start with the switch (1) in upper, middle, and down position, then the start keyboard (9) from the left upper key to the right until you reached the right bottom key. Afterwards do the same test with the function keyboard (14) and the finish keyboard (15).

Leave the keyboard test by pressing <ALT> and <ENTER> (finish keyboard 15) at the same time.

Channel Test:

to test the channels

Menu 38
ALGE TIMING
MULTICHANNEL MC18

Interface Test:

to test the interface

Menu 39

RAM Test:

to test the RAM

Menu 40

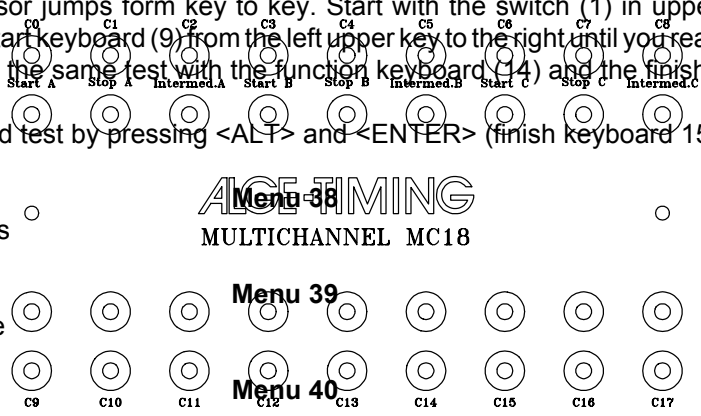

RTC Test:

to test the real time clock

Menu 41

Low Voltage Test:

to test the low voltage barriers for power down

Menu 42

Exit the TdC TEST by switching the device off.

7. DESCRIPTION OF ADDITIONAL DEVICES

7.1. Multi Channel MC18:

You can use the MC18 if you want to connect many channels. The MC18 has all 10 TdC 8000 channels on banana sockets (c0 to c9). For the TdC 8000 is channel c10 to c17 not active. Connect the MC18 at the TdC socket "multi channel" (16).

8.2. Opto Channel OC18:

Use the OC18 if you need potential free contacts. The OC18 prevents the TdC 8000 from damage through high voltage coming through the impulse cables.

The OC18 has all 10 TdC 8000 channels on banana sockets (channel c0 to c9). Channel c10 to c17 is not activated. Connect the OC18 at the socket "multi channel" (16) of the TdC 8000.

The Opto Channel OC18 has a 9 V battery built in. To change the battery you have to unscrew the cover.

8. TECHNICAL DATA

Measuring range: 23 hours, 59 minutes, 59,9999 seconds

Crystal frequency: TCXO 11.520 MHz (Temperature Compensated Crystal Oscillator)

Accuracy:

at changeable temperature range from -25 to +50°C: +/- 2,5 ppm at (+/- 0,009 s/h.)
Aging: +/- 1 ppm per year
Frequency adjustment: +/- 0,1 ppm at 25°C

Temperature Operative Timing Range:: -25 to 50°C

Memory: about 2 x 8.600 times with start numbers;
keeps data when switched off through internal rechargeable battery

Display:

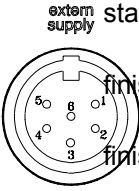
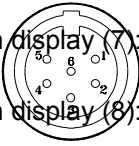
	start display (2):	numeric liquid crystal display, 8 digits, figure height 12.7 mm,
	finish display (7):	numeric liquid crystal display, 8 digits, figure height 12.7 mm,
	finish display (8):	numeric liquid crystal display, 8 digits, figure height 12.7 mm,
	info-display (6):	alphanumeric liquid crystal display 4 x 40 characters, figure height 4.8 mm

Operating elements:

- On-/Off-switch (26)
- Turn over switch (1)
- Start Keyboard (9)
- Function Keyboard (14)
- Finish Keyboard (15)

Electronic: most advanced C-MOS technology with 80C166 microprocessor

Power supply:

internal: NiCd rechargeable battery 7.2 V / 4.5 A
external: 210 to 240 VAC with Net-Charging-Device NLG8

Power consumption:

without external devices from the internal NiCd battery: about 80 mA

when printing: about 500 mA

Charging supply: +11 to 16 VDC (Pin 4 from socket 19, 20, 21 and 22)

Impulse length:

Input resistance 10 kΩ against +5V
Triggering with < 1V (falling flank)
Hysteresis about 2V

Output 5VDC stabilized: total max. of 120 mA

Loudspeaker output: for 8 Ω speaker, $U_{max} = 24 V_{pp}$

Casing: case with key to lock, top you can take away
front panel of aluminium

Dimensions: 450 x 320 x 150 mm

Weight: 7.5 kg

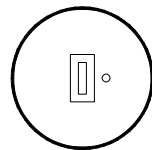
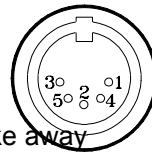

8.1. Connection System:

8.1.1. Photocell jacks and external supply:

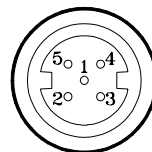

Jack A and A' (20 and 19):

- 1 input channel 0 (start)
- 2 input channel 1 (stop)
- 3 common ground
- 4 input external supply (6 to 15 VDC)
- 5 output +5 VDC stabilized
- 6 input channel 2 (intermediate time)

Jack B (21):

- 1 input channel 3 (start)
- 2 input channel 4 (stop)
- 3 common ground
- 4 input external supply (6 to 15 VDC)
- 5 output +5 VDC stabilized
- 6 input channel 5 (intermediate time)

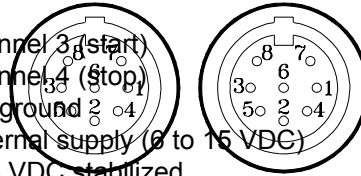

Jack C (22):

- 1 input channel 6 (start)
- 2 input channel 7 (stop)
- 3 common ground
- 4 input external supply (6 to 15 VDC)
- 5 output +5 VDC stabilized
- 6 input channel 8 (intermediate time)



8.1.2. Headset Jack (18):

- 1 microphone of headset
- 2 common ground
- 3 loud speaker of headset
- 4 common ground
- 5 input channel 9

8.1.3. Speaker Jack (25):

- 1 speaker signal
- 2 common ground

8.1.4. Display Board Jack (24):

- 1 common ground
- 2 output supply (6 to 15 VDC)
- 3 output data channel 1
- 4 output supply (6 to 15 VDC)
- 5 output data channel 1 or 2

8.1.5. RS 232 / RS 485 (23):

- 1 RS 232, Data TXD (transmit)
- 2 RS 232, common ground
- 3 RS 232, Data RXD (receive)
- 4 RS 232, CTS
- 5 RS 232, RTS
- 6 RS 485, line a

- 7 RS 232, output external supply (6 to 15 VDC)
- 8 RS 485, line b

8.1.6. Display Board (28):

Display board interface with data output channel 2 (yellow (or withe) banana socket) and ground (black (or blue) banana socekt).

8.1.7. Banana Socket for Channel 0 to 9 (27):

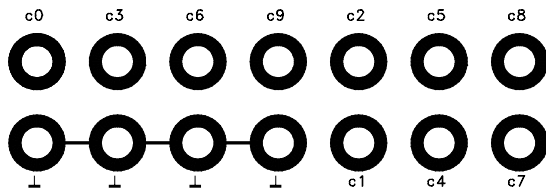

All channels you can connect on the banana sockets. For all 9 channel you have four ground connections.

8.1.8. Multi Channel (16):

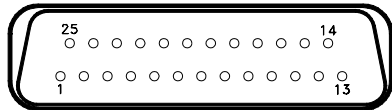

- | | |
|---|---|
| 1 channel 9 | 13 output +5 VDC stabilized |
| 2 channel 0 (start) | 14 channel 1 |
| 3 channel 2 | 15 channel 5 |
| 4 channel 3 | 16 channel 8 |
| 5 channel 7 | 17 channel 6 |
| 6 data output (like channel 2 from "display board" (24) | 18 channel 4 |
| 7 RS 485 B | 19 empty |
| 8 RS 485 A | 20 empty |
| 9 Clock A | 21 empty |
| 10 Clock B | 22 empty |
| 11 empty | 23 output external supply (5.3 to 14.3 VDC) |
| 12 common ground | 24 common ground |
| | 25 external supply (+6 to 15 VDC) |

8.2. RS 232 Interface (16, 23):

Transfer Format: 1 start bit, 8 data bit, no parity bit, 1 stop bit
Transfer Speed: 9.600 Baud pre adjusted (adjustable: 2400, 4800)
Transfer Protocol: ASCII

xNNNNxCCxxHH:MM:SS.zhtqxGR (CR)	time from C0 to C9
xNNNNxCCMxxHH:MM:SS.zhtqxGR (CR)	manual time from <START> or <STOP> button
xNNNNxRTxxHH:MM:SS.zhtxxGR (CR)	run time
xNNNNxTTxxHH:MM:SS.zhtxxGR (CR)	total time
xNNNNxSQxxHH:MM:SS.zhtxxGR (CR)	sequential time (lap time)
xNNNNiCCxxHH:MM:SS.zhtxxGR (CR)	Dual Timer, times form C0 to C9
xNNNNiRTxxHH:MM:SS.zhtxxGR (CR)	Dual Timer, run time
xNNNNiCCxxHH:MM:SS.zhtqx## (CR)	Parallelslalom, Intermediate Time or Finish Time
xNNNNiRTxxHH:MM:SS.zhtqx## (CR)	Parallelslalom, Run Time
xNNNNiDTRxxHH:MM:SS.zhtxx## (CR)	Parallelslalom, Difference Time of Run
xNNNNiTxxHH:MM:SS.zhtqx## (CR)	Parallelslalom, Total Time
xNNNNiDTTxxHH:MM:SS.zhtxx## (CR)	Parallelslalom, Total Difference Time
pNNNNiCCxxHH:MM:SS.zhtqx## (CR)	Parallelslalom, Finish Time calculated form Penalty Time
pNNNNiRTxxHH:MM:SS.zhtqx## (CR)	Parallelslalom, Run Time calculated form Penalty Time
pNNNNiTxxHH:MM:SS.zhtqx## (CR)	Parallelslalom, Total Time calculated form Penalty Time
xNNNNxkmhxxxxs:sss.ssxxxGR (CR)	speed measurement
xNNNNxkmhxxxxs:sss.ssxxxx (CR)	speed measurement for speed skiing
?NNNNxCCxxHH:MM:SS.zhtqxGR (CR)	illegal time
m0000xCCxxHH:MM:SS.zhtqxGR (CR)	times stopped with <MEMO>
cNNNNxCCxxHH:MM:SS.zhtqxGR (CR)	cleared time
dNNNNxCCxxHH:MM:SS.zhtqxGR (CR)	disqualified time
iNNNNxCCxxHH:MM:SS.zhtxxGR (CR)	manipulated time (<INPUT>)
xxxxxxC0xxHH:MM:SS.zhtqxGR (CR)	start time after a group start
nNNNN (CR)	new start number shown in finish display (8)

x	blank		
NNNN	start number (four digits)		
0000	start number 0 for times stopped with <MEMO>		
i	Identification of the course; r (= red/right), b (= blue) or l (left) course		
CC	timing channels (c0 to c9)		
CCM	manual impulse (with <START> or <STOP> from keyboard 9 or 15)		
C0	channel 0 (start)	C5	channel 5
C1	channel 1 (finish)	C6	channel 6
C2	channel 2	C7	channel 7
C3	channel 3	C8	channel 8
C4	channel 4	C9	channel 9
RT	run Time		
TT	total Time		
SQ	sequential Time (lap time)		
DTR	difference time of run		
DTT	total difference time		
kmh	speed (possible output depending on unit used: kmh, mps, mph)		
HH:MM:SS.zht	time in hours, minutes, seconds, and 1/1000 seconds		
HH:MM:SS.zhtq	time in hours, minutes, seconds, and 1/10000 seconds		
sssss.ss	speed for 0.00 up to 99999.99 measured in km/h in speed skiing		
GR	group (from 01 to 99, no input for groups = 00)		
##	countinuos number for each lap		
(CR)	Carriage Return		

The following characters could be the first digit:

- x blank
- ? time without valid start number
- m time from memo (memory)
- c cleared time (with <CLEAR>)
- d times cleared through disqualification
- i times input manual: <INPUT>
- n new start number shown in finish display (8)

- p calculated time from Penalty Time

8.2.1. Checking the TdC 8000 adjustments through the RS 232 interface:

Pin arrangement: see page 95

You can check the following adjustments through the RS 232 interface:

Cable form TdC 8000 to PC (9-Pin):

067-02

Cable form TdC 8000 to PC (25-Pin):

066-03

Precision:

- RS232 question: PRE=?
- TdC 8000 answer: PRE = 1 s
- precision is 1 second
- PRE = 1/10 s
- precision is 1/10 seconds
- PRE = 1/100 s
- precision is 1/100 seconds
- PRE = 1/1000 s
- precision is 1/1000 seconds

In the main menu you can adjust the following:

RS 232 Baudrate:

Menu 15:

RS-232 BAUDRATE = 9600 Bd

You can adjust the baud rate of the RS 232 interface (23) between 2400, 4800, or 9600 baud.

Pre adjusted value: 9600 Baud

Timing Mode:

- RS232 question: TI=?
- TdC 8000 answer: TI = DIFFERENC
- difference timing
- TI = ABSOLUT
- absolute timing

Laps for the Split-Sequential program:

- RS232 question: LAPS = ?
- TdC 8000 answer: LAPS = 4
- Adjusted amount of laps (1 to 99)

RS 232 Run Time:

Menu 16:

RS-232 RUN TIME = OFF

The RS 232 interface (23) outputs always in the difference-timing mode the time of day. Additional you can output the run time.

- output time of day and run time =
- <F1>
- output time of day =
- <F2>

Pre adjusted value: RS-232 output is time of day

8.2.2. Adjustment of the Main Menu through the RS 232 interface:

You can adjust the main menu direct from a PC through the RS 232 interface.

Delay Time Start: Menu 1

- RS232 question: DTS?
- RS232 order: DTS=0.30
- Adjustable: 0,00 to 9,99 seconds

Delay Time Finish: Menu 2

- RS232 question: DTF?
- RS232 order: DTS=0.30
- Adjustable: 0,00 to 9,99 seconds

Seconds Mode: Menu 3
 RS232 question: SM?
 RS232 order: SM=ON
 Adjustable: ON or OFF

Display Time 1: Menu 4
 RS232 question: DIT1?
 RS232 order: DIT1=03
 Adjustable: 0 to 99 seconds

Display Time 2: Menu 5
 RS232 question: DIT2?
 RS232 order: DIT2=03
 Adjustable: 0 to 99 seconds

Display Thousandth: Menu 6
 RS232 question: DI1/1000?
 RS232 order: DI1/1000=ON
 Adjustable: ON or OFF

Info-Display: Menu 7
 RS232 question: IDIS?
 RS232 order: IDIS=START
 Adjustable: START, FINISH, or OFF

Running Time: Menu 8
 RS232 question: RT?
 RS232 order: RT=RUN
 Adjustable: RUN or Total

Running Tenth: Menu 9
 RS232 question: R1/10?
 RS232 order: R1/10=OFF
 Adjustable: ON or OFF

Intermediate Rank: Menu 10
 RS232 question: RNKIT?
 RS232 order: RNKIT=ON
 Adjustable: ON or OFF

Finish Rank: Menu 11

RS232 question: BDDDB?
 RS232 order: RTRS=OFF
 Adjustable: ON or OFF

Display Board Channel 2: Menu 19
 RS232 question: DBC2?
 RS232 order: DBC2=RUNNING
 Adjustable: RUNNING or STANDING

Beep: Menu 20
 RS232 question: BEEP?

RS232 question: RNKFT?
 RS232 order: RNKFT=ON
 Adjustable: ON or OFF

Start Number Automatic: Menu 12
 RS232 question: STNOA?
 RS232 order: STNOA=OFF
 Adjustable: OFF, START, or FINISH

Print Start Time: Menu 13
 RS232 question: PST?
 RS232 order: PST=OFF
 Adjustable: ON or OFF

Print Menus: Menu 14
 RS232 question: PM?
 RS232 order: PM=ON
 Adjustable: ON or OFF

Print Linefeed: Menu 15
 RS232 question: PLF?
 RS232 order: PLF=ON
 Adjustable: ON or OFF

RS 232 Baudrate: Menu 16
 RS232 question: BDRS?
 RS232 order: BDRS=9600
 Adjustable: 2400, 4800, or 9600 Bd

RS 232 Run Time: Menu 17
 RS232 question: RSRT?
 RS232 order: RSRT=OFF
 Adjustable: ON or OFF

Display Board Baud Rate: Menu 18

RS232 order: BEEP=ON
Adjustable: ON or OFF

Handicap Time: Menu 21

RS232 question: HT?
RS232 order: HT=00:01:12.34
Adjustable: time in 1/100 seconds
Handicap off: HT=00:00:00.000

Input of Groups: Menu 22

RS232 question: not possible
RS232 order: not possible

Change Run: Menu 23

RS232 question: not possible
RS232 order: not possible

Change Race: Menu 24

RS232 question: not possible
RS232 order: not possible

Display Board Test: Menu 25

RS232 question: not possible
RS232 order: not possible

Penalty Time for Parallel Slalom: Menu 26

RS232 question: PT?
RS232 order: PT=1.500
Adjustable: seconds and 1/1000 sec.

ID for Channel 4 in Parallel Slalom: Menu 27

RS232 question: IDC4?
RS232 order: IDC4=BLUE
Adjustable: B or L (blue or left)

Start Channel for Dual Timer: Menu 28

RS232 question: STS?
RS232 order: STS=SEPARATE
Adjustable: SEPARATE or COMMON

Ranking for Dual Timer: Menu 29

RS232 question: RNKC?
RS232 order: RNKC=SEPARATE
Adjustable: SEPARATE or COMMON

Printing Times for Speed: Menu 30

RS232 question: PRT?
RS232 order: PRT=OFF
Adjustable: OFF or ON

Measuring Distance Speed: Menu 31

RS232 question: DST?
RS232 order: DST=0100
Adjustable: 1 to 9999

Measuring Unit for Speed: Menu 32

RS232 question: SPU?

RS232 order: SPU=kmh
 Adjustable: kmh, m/s or mph

Min. Speed: Menu 33

RS232 question: MINSP?
 RS232 order: MINSP=0010
 Adjustable: 1 to 9999

Max. Speed: Menu 34

RS232 question: MAXSP?
 RS232 order: MAXSP=0200
 Adjustable: 1 to 9999

8.2.3. Call Data through the RS 232 Interface:

Through the RS 232 interface you can call all data of the memory of the TdC 8000 e.g. from a PC. Each command is closed with a Carriage Return (in the following examples it is listed as (CR)).

If you want a classement of intermediate times, you must identify the channel number (C2 to C9).

If you want a "SINGLE" classement, you need to input also the data that you want transferred (e.g. start numbers, start number blocks, groups).

Classement "NOT FINISHED":

NOF (CR) all competitors that did not finished the race

Classement "DISQUALIFIED":

DIS (CR) all disqualified competitors

Classement "START ORDER":

STO (CR) Start order for the 2nd heat (for BIBO)

Classement "ALL:

- CALRT (CR) Classement of the run time from all competitors
- CAL01RT (CR) Classement of all run times of a lap (01 = lap 1)
- CAL01SQ (CR) Classement of all sequential times of a lap (01 = lap 1)
- CALMT (CR) Classement of the memory time from all competitors
- CALTT (CR) Classement of the total time from all competitors
- CALITC2 (CR) Classement of the intermediate time C2 from all competitors
- CALITC3 (CR) Classement of the intermediate time C3 from all competitors
- CALITC4 (CR) Classement of the intermediate time C4 from all competitors
- CALITC5 (CR) Classement of the intermediate time C5 from all competitors
- CALITC6 (CR) Classement of the intermediate time C6 from all competitors
- CALITC7 (CR) Classement of the intermediate time C7 from all competitors
- CALITC8 (CR) Classement of the intermediate time C8 from all competitors
- CALITC9 (CR) Classement of the intermediate time C9 from all competitors
- CALBRT (CR) Classement of all competitor of the BLUE course for Dual Timer
- CALRRT (CR) Classement of all competitor of the RED (right) course for Dual Timer
- CALLRT (CR) Classement of all competitor of the left course for Dual Timer

Classement "GROUPS" and "ALL"

- CGRALRT (CR) Group classement of the run time from all groups
- CGRALMT (CR) Group classement of the memory time from all groups
- CGRALTT (CR) Group classement of the total time from all groups
- CGRALITC2 (CR) Group classement of the intermediate time C2 from all groups
- CGRALITC3 (CR) Group classement of the intermediate time C3 from all groups
- CGRALITC4 (CR) Group classement of the intermediate time C4 from all groups

- CGRALITC5 (CR) . . Group classement of the intermediate time C5 from all groups
- CGRALITC6 (CR) . . Group classement of the intermediate time C6 from all groups
- CGRALITC7 (CR) . . Group classement of the intermediate time C7 from all groups
- CGRALITC8 (CR) . . Group classement of the intermediate time C8 from all groups
- CGRALITC9 (CR) . . Group classement of the intermediate time C9 from all groups
- CGRALLBRT (CR) . . Group classement of the BLUE course for Dual Timer
- CGRALLRRT (CR) . . Group classement of the RED (right) course for Dual Timer
- CGRALLLRT (CR) . . Group classement of the left course for Dual Timer

Classement "GROUPS" and "SINGLE":

After the instruction for "GROUPS" and "SINGLE" you must input the groups. Input each group with a 2 character number and confirm it with a carriage return. Input after the last group 00 and a carriage return.

- CGRSIRT (CR) Group classement of the run time from selected groups
- CGRSIMT (CR) Group classement of the memory time from selected groups
- CGRSITT (CR) Group classement of the total time from selected groups
- CGRSIITC2 (CR) . . Group classement of the intermediate time C2 from selected groups
- CGRSIITC3 (CR) . . Group classement of the intermediate time C3 from selected groups
- CGRSIITC4 (CR) . . Group classement of the intermediate time C4 from selected groups
- CGRSIITC5 (CR) . . Group classement of the intermediate time C5 from selected groups
- CGRSIITC6 (CR) . . Group classement of the intermediate time C6 from selected groups
- CGRSIITC7 (CR) . . Group classement of the intermediate time C7 from selected groups
- CGRSIITC8 (CR) . . Group classement of the intermediate time C8 from selected groups
- CGRSIITC9 (CR) . . Group classement of the intermediate time C9 from selected groups
- CGRSILBRT (CR) . . Group classement of the BLUE course for Dual Timer from selected groups
- CGRSILRRT (CR) . . Group classement of red (right) course from selected groups (Dual Timer)
- CGRSILLRT (CR) . . Group classement of the left course for Dual Timer from selected groups
- 01(CR)..... e.g. group 1
- 04(CR)..... e.g. group 4
- 07(CR)..... e.g. group 7
- 00(CR)..... finish with this input

Classement "CLASS":

After the instruction for "CLASSES" input the classes. You can make a class out of different start number blocks. Each start number block has the first and last start number (each four digits) of a continues sequence. Both start numbers are separated by a hyphen. Each number block is separated by a carriage return. Input after the last number block 0000-0000 and carriage return.

- CCLRT (CR) Classement of the run time from start number blocks (classes)
- CCL01RT (CR) Classement of run times of a lap (01=lap) from start number blocks (classes)
- CCL01SQ (CR) Classement of sequential times of a lap (01 = lap 1) from start number blocks
- CCLMT (CR) Classement of the memory time from start number blocks (classes)
- CCLTT (CR) Classement of the total time from start number blocks (classes)
- CCLITC2 (CR) Classement of the intermediate time C2 from start number blocks (classes)
- CCLITC3 (CR) Classement of the intermediate time C3 from start number blocks (classes)
- CCLITC4 (CR) Classement of the intermediate time C4 from start number blocks (classes)
- CCLITC5 (CR) Classement of the intermediate time C5 from start number blocks (classes)
- CCLITC6 (CR) Classement of the intermediate time C6 from start number blocks (classes)
- CCLITC7 (CR) Classement of the intermediate time C7 from start number blocks (classes)
- CCLITC8 (CR) Classement of the intermediate time C8 from start number blocks (classes)
- CCLITC9 (CR) Classement of the intermediate time C9 from start number blocks (classes)
- CCLBRT (CR) Classement of the run time from blocks (classes) from the blue course (Dual Timer)
- CCLRRT (CR) Classement of the run time from blocks (classes) from the red (right) course (Dual Timer)
- CCLLRT (CR) Classement of the run time from blocks (classes) from the left course (Dual Timer)
- 0001-0024 (CR) . . Start number block, e.g. form StNo. 1 to StNo. 24
- 0065-0073 (CR) . . Start number block, e.g. form StNo. 65 to StNo. 73

0105-0124 (CR) . . . Start number block, e.g. form StNo. 105 to StNo. 124
 0000-0000 (CR) . . . Finish with this input

Classement "LEADING TEN":

CFTRT (CR) Classement of the leading ten run times
 CFT01RT (CR) Classement of the leading ten run times of a lap (01=lap)
 CFT01SQ (CR) Classement of the leading ten sequential times of a lap (01 = lap 1)
 CFTMT (CR) Classement of the leading ten memory times
 CFTTT (CR) Classement of the leading ten total times
 CFTITC2 (CR) Classement of the leading ten intermediate times from channel C2
 CFTITC3 (CR) Classement of the leading ten intermediate times from channel C3
 CFTITC4 (CR) Classement of the leading ten intermediate times from channel C4
 CFTITC5 (CR) Classement of the leading ten intermediate times from channel C5
 CFTITC6 (CR) Classement of the leading ten intermediate times from channel C6
 CFTITC7 (CR) Classement of the leading ten intermediate times from channel C7
 CFTITC8 (CR) Classement of the leading ten intermediate times from channel C8
 CFTITC9 (CR) Classement of the leading ten intermediate times from channel C9
 CFTBRT (CR) Classement of the leading ten of the BLUE course for Dual Timer
 CFTRRT (CR) Classement of the leading ten of the RED (right) course for Dual Timer
 CFTLRT (CR) Classement of the leading ten of the left course for Dual Timer

Classement "SINGLE":

After the instruction for "SINGLE" you must input the start numbers. Input each start number with a 4 character number and confirm it with a carriage return. Input after the last number 0000 and a carriage return.

CSIRT (CR) Classement of the run time of individual start numbers
 CSI01RT (CR) Classement of the run time of a lap (01=lap) with individual start numbers
 CSI01SQ (CR) Classement of the sequential times of a lap with individual start numbers
 CSIMT (CR) Classement of the memory time of individual start numbers
 CSITT (CR) Classement of the total time of individual start numbers
 0001 (CR) input start number
 0005 (CR) input start number
 0012 (CR) input start number
 0000 (CR) finish with this input

Classement "ADD":

After the instruction for "ADD" you must input the start numbers that you want added. Input each start number with a 4 character number and confirm it with a carriage return. Input after the last number 0000 and a carriage return.

CADRT (CR) Add run times from competitors
 CAD01RT (CR) Add run times of a lap (01=lap) from competitors
 CAD01SQ (CR) Add sequential times of a lap (01 = lap 1) from competitors
 CADMT (CR) Add memory times from competitors
 CADTT (CR) Add total times from competitors
 CADITC2 (CR) Add intermediate times from channel C2 from competitors
 CADITC3 (CR) Add intermediate times from channel C3 from competitors
 CADITC4 (CR) Add intermediate times from channel C4 from competitors
 CADITC5 (CR) Add intermediate times from channel C5 from competitors
 CADITC6 (CR) Add intermediate times from channel C6 from competitors
 CADITC7 (CR) Add intermediate times from channel C7 from competitors
 CADITC8 (CR) Add intermediate times from channel C8 from competitors
 CADITC9 (CR) Add intermediate times from channel C9 from competitors

0001 (CR) input start number
 0005 (CR) input start number
 0012 (CR) input start number
 0025 (CR) input start number
 0000 (CR) finish with this input

Classement "PROTOCOL" and "ALL":

PALST (CR) Protocol of all start times
 PALFT (CR) Protocol of all finish times
 PALRT (CR) Protocol of all run times
 PALSQ (CR) Protocol of all sequential times (lap times)
 PALMT (CR) Protocol of all memory times
 PALTT (CR) Protocol of all total times
 PALITC2 (CR) Protocol of all intermediate times of channel C2
 PALITC3 (CR) Protocol of all intermediate times of channel C3
 PALITC4 (CR) Protocol of all intermediate times of channel C4
 PALITC5 (CR) Protocol of all intermediate times of channel C5
 PALITC6 (CR) Protocol of all intermediate times of channel C6
 PALITC7 (CR) Protocol of all intermediate times of channel C7
 PALITC8 (CR) Protocol of all intermediate times of channel C8
 PALITC9 (CR) Protocol of all intermediate times of channel C9
 PALBRT (CR) Protocol of all run times of the blu course for Dual Timer
 PALRRT (CR) Protocol of all run times of the red (right) course for Dual Timer
 PALLRT (CR) Protocol of all run times of the left course for Dual Timer

Classement "PROTOCOL" and "SINGLE":

After the instruction for "PROTOCOL" and "SINGLE" input the start number blocks. You can use more than one start number block. Each start number block has the first and last start number (each four digits) of a continuous sequence. Both start numbers are separated by a hyphen. Each number block is separated by a carriage return. Input after the last number block 0000-0000 and carriage return.

PSIST (CR) Protocol of selected start times
 PSIFT (CR) Protocol of selected finish times
 PSIRT (CR) Protocol of selected run times
 PSISQ (CR) Protocol of selected sequential times (lap times)
 PSIMT (CR) Protocol of selected memory times
 PSITT (CR) Protocol of selected total times
 PSIIITC2 (CR) Protocol of selected intermediate times of channel C2
 PSIIITC3 (CR) Protocol of selected intermediate times of channel C3
 PSIIITC4 (CR) Protocol of selected intermediate times of channel C4
 PSIIITC5 (CR) Protocol of selected intermediate times of channel C5
 PSIIITC6 (CR) Protocol of selected intermediate times of channel C6
 PSIIITC7 (CR) Protocol of selected intermediate times of channel C7
 PSIIITC8 (CR) Protocol of selected intermediate times of channel C8
 PSIIITC9 (CR) Protocol of selected intermediate times of channel C9
 PSIBRT (CR) Protocol of selected run times of the blue course for Dual Timer
 PSIRRT (CR) Protocol of selected run times of the red (right) course for Dual Timer
 PSILRT (CR) Protocol of selected run times of the left course for Dual Timer
 0001-0024 (CR) .. Start number block, e.g. form StNo. 1 to StNo. 24
 0065-0073 (CR) .. Start number block, e.g. form StNo. 65 to StNo. 73
 0105-0124 (CR) .. Start number block, e.g. form StNo. 105 to StNo. 124
 0000-0000 (CR) .. Finish with this input

8.3. RS 485 Interface (16, 23, 28): no function

Transfer Speed: 60 kBaud

Pin Arrangement: see page 95

8.4. Display Board Interface (24):

Transfer Format: 1 start bit, 8 data bit, no parity bit, 1 stop bit
Transfer Speed: 2.400 Baud
Transfer Protocol: ASCII

The display board interface has two different channels:

Channel 1: running time

Channel 2: running time and clasement or run time and clasement

Attention: Switch between channel 1 and channel 2 by turning the plug of socket (24) 180°.

Channel 1 has always the same output as shown in display 7 and 8. The adjusted display time (see menu 4 on page 52) is always valid for display 7 and 8 and channel 1 of the display board interface (24). Channel 1 does not output a clasement.

You can switch channel 2 in the main menu (menu 19 on page 56) between running and standing time (run time). On channel 2 you have always an output of the clasement.

NNN .xxxxxxxxxM : SSxxxx (CR)	running time (without 1/10 seconds)
NNN .xxxxHH : MM : SSxxxx (CR)	running time (without 1/10 seconds)
NNN .xxxxHH : MM : SS . zxx (CR)	running time (with 1/10 seconds)
NNNCxxxxHH : MM : SS . zhtRR (CR)	channel C1, run time with rank
NNNCxxxxHH : MM : SS . zhtxx (CR)	channel C1, run time without rank
NNNDxxxxHH : MM : SS . zhtRR (CR)	channel C1, total time with rank
NNNDxxxxHH : MM : SS . zhtxx (CR)	channel C1, total time without rank
NNNAxxxxHH : MM : SS . zhtRR (CR)	channel C2, intermediate time 1
NNNBxxxxHH : MM : SS . zhtRR (CR)	channel C3, intermediate time 2
NNNExxxxHH : MM : SS . zhtRR (CR)	channel C4, intermediate time 3
NNNFxxxxHH : MM : SS . zhtRR (CR)	channel C5, intermediate time 4
NNNGxxxxHH : MM : SS . zhtRR (CR)	channel C6, intermediate time 5
NNNHxxxxHH : MM : SS . zhtRR (CR)	channel C7, intermediate time 6
NNNIxxxxHH : MM : SS . zhtRR (CR)	channel C8, intermediate time 7
NNNJxxxxHH : MM : SS . zhtRR (CR)	channel C9, intermediate time 8
NNNSxxx©xxxxsxss . ssxRR (CR)	Speed
ANNNxxxxxHH : MM : SS . zhtRR (CR)	sequential time for program Split-Sequential

NNN start number (3 digit)
 a point on the fourth digit is the identification for a running time
 A,B,C, ...,H,I,J address for display board (digit 1)
 A,B,C, ...,H,I,J identification of the channel (digit 4)
 HH:MM:SS.zht time in hours, minutes, seconds, and 1/1000 seconds
 © speed measurement: output of the following ASCII characters
 01 Hex. for km/h, 02 Hex. for m/s, 03 Hex. for mph
 RR rank
 x blank
 (CR) carriage return

Pin Arrangement: see on page 94

Cable from TdC 8000 to display board GAZ4: 010-10

Cable form TdC 8000 to Teledata TED-TX with supply: 107-10

In the main menu you can do the following adjustment for the display board interface (24):

Display Time 1: Menu 4: DISPLAY TIME 1 = 03 s

You can adjust the amount of time that it shows a stopped time on the display (7) or display board. This time we call display time 1. You can select the display time between 0 and 99 seconds.

Menu 4: DISPLAY Time 1 = <u>03</u> s	input seconds with finish keyboard (15)
Save with: ENTER	Confirm input with <ENTER>

Pre adjusted value: Display Time 1 = 3 seconds

Display Time 2: Menu 5: DISPLAY TIME 2 = 03 s

You can adjust the amount of time that it shows the second stopped time in the second heat (total time or run time) on the display (7) or display board. This time we call display time 2. You can select the display time between 0 and 99 seconds.

Menu 5: DISPLAY Time 2 = <u>03</u> s	input seconds with finish keyboard (15)
Save with: ENTER	Confirm input with <ENTER>

Pre adjusted value: Display Time 2 = 3 seconds

Display Board Channel 2: Menu 18: D-BOARD CHANNEL 2 = OFF

You can adjust the channel 2 of the display board interface (24). If you have channel two on it outputs no running time (only run times). It outputs the clasement always on channel 2. You can select between channel 1 and channel 2 by turning the plug of the display board cable 180°.

Menu 18: D-BOARD CHANNEL 2 ON F1	output of run times
OFF< F2	output of running time
Save with: ENTER	Confirm selection with <ENTER>

- ON = <F1> run time and clasement
- OFF = <F2> running time and clasement

Pre adjusted value: D-Board Channel 2 is off (running time)